

AC & DC Stackers

(B, D, E, and PS Series)

Installation, Operation & Service Manual

Model Number _____

Serial # _____

Date placed in service _____

IMPORTANT: READ CAREFULLY
BEFORE INSTALLING OR OPERATING LIFT



Presto Lifts Limited Warranty Policy

Presto Lifts warrants all of its products against defects in the welded structural frame and, if applicable, scissor legs from faulty material and workmanship for a period of five (5) years from the date of invoice.

All batteries and battery chargers have a limited warranty against defects in faulty material and workmanship for a ninety (90) day period from the date of invoice through Presto Lifts. All other components have a limited warranty against defects in faulty material and workmanship for a two (2) year period from the date of invoice and a 30 day limited warranty on labor. Please note that prior authorization from Presto Lifts is required on all warranty work.

There are no implied warranties of any kind, more specifically, there are no warranties of merchantability or fitness for any particular purpose. Presto Lifts' sole warranty shall be as set forth in this limited warranty.

Presto Lifts will elect to repair or replace a defective component without charge, if any components should become defective within the limited warranty period. Proof of purchase is required for warranty. The charge for shipping the defective component is the responsibility of the buyer and must be accompanied with an RMA number. The shipping charge to return the component to the buyer is the responsibility of Presto Lifts, Inc.

This limited warranty does not cover labor expense for removal or reinstallation of components after thirty days. This limited warranty shall not cover, among other things: damages resulting from foreign matter or water, failure to provide reasonable and necessary maintenance, and if applicable, use of product while charger is plugged into an AC outlet, or failure to follow operating instructions. The limited warranty is not valid for damage resulting from negligence, accident, unreasonable use, abuse or misuse, exceeding data plate capacities or altering the product without Presto Lifts authorization.

Presto Lifts expressly disclaims and excludes any liability for consequential, incidental, indirect or punitive damages or financial loss to people or property resulting from any breach of warranty or the operation or failure of this product.

Presto Lifts makes no representation that this product complies with local, state, or federal safety/product standards codes. Should this product fail to comply in any way with those codes, it shall not be considered a defect of materials or workmanship. Presto Lifts shall not be held liable for any damages resulting from noncompliance. It is the dealer's responsibility to exercise this limited warranty. This limited warranty is provided to the original purchaser (defined as the original end user) and is nontransferable. This constitutes the complete and final agreement involving Presto Lifts and limited warranty obligations for products.

This manual was current at the time of printing. To obtain the latest, most updated version, please contact the Customer Service Department or go to our website: www.PrestoLifts.com -- you will find a complete list of current owner's manuals to print.

CONTENTS

SECTION 1:	
Warranty.....	2
Introduction.....	4
Responsibility of Owners and Users.....	5
Safety Labels and Markings.....	6
SECTION 2:	
Safety	7
SECTION 3:	
Installation.....	7
SECTION 4:	
Operation.....	7
A. Operating Instructions	
B. Daily Operations Maintenance Checks	
SECTION 5:	
Maintenance.....	8
A. Instructions	
B. Monthly Operations Maintenance Checks	
SECTION 6:	
Troubleshooting	10
ORDERING PARTS.....	27
RESTOCKING POLICY.....	28
RMA POLICY	29

LIST OF FIGURES

Chain Roller Assemblies (Figure 1)	10
5th Wheel Assembly (Figure 2A, 2B & 2C)	11-12
1,000 lb. Capacity Cylinder Breakdown (Figure 3A) previous to March 2000	13
2,000 lb. Capacity Cylinder Breakdown (Figure 3B) previous to March 2000.....	14
2,000 lb. Capacity Cylinder Breakdown (Figure 3C)	15
DC Power Wiring Schematic - Standard (Figure 4)	16
Standard DC Power Pack Illustration (Figure 5)	17
DC Power Pack w/ Remote Control Illustration (Figure 6)	17
Old Style Standard AC Power Pack Illustration (Figure 7)	18
Old Style AC Power Pack w/ Remote Control Illustration (Figure 8)	18
DC Wiring Schematic w/ Remote Control (Figure 9)	19
AC Wiring Schematic w/ Remote Control (Figure 10A)	19
New Style DC Power Pack (Figure 10B & 10C).....	20-21
Generic Floor Lock Assembly (Figure 11)	22
Bearing Bracket Assembly (Figure 12)	22
Pallet Straddle Stacker Illustration - Front View(Figure 13)	23
Pallet Straddle Stacker Illustration - Back View (Figure 14)	24
Standard Replacement Component Listing	25
Labels and Locations (Figure 15).....	26
Hydraulic Oil Specifications (Table 1).....	27

SECTION 1

INTRODUCTION

This manual attempts to provide all of the information necessary for the safe and proper installation, operation and maintenance of Presto Lifts Battery Operated and Electric Stackers. It is important that all personnel involved with the installation, maintenance or operation of the stacker read this manual. Additional manuals are available upon request or at www.prestolifts.com.

Each of the Presto Lift stackers is equipped with nameplate, serial number and model identifications. Please refer to these numbers when ordering parts or requesting further information.

The Presto Lifts stackers are designed for lifting, lowering and positioning a wide variety of loads. WHERE UNIQUE SITUATIONS ARISE, WHICH ARE NOT COVERED IN THIS MANUAL, CALL PRESTO LIFTS FOR FURTHER INSTRUCTIONS.

The battery-operated stackers are designed for in-plant/nonhazardous locations only. These units are not for personnel lifting. All equipment is manually propelled and powered vertical travel.

Responsibility of Owners and Users

Inspection and Maintenance

The device shall be inspected and maintained in proper working order in accordance with Presto's owner's manual.

Removal from Service

Any device not in safe operating condition such as, but not limited to, excessive leakage, missing rollers, pins, or fasteners, any bent or cracked structural members, cut or frayed electric, hydraulic, or pneumatic lines, damaged or malfunctioning controls or safety devices, etc. shall be removed from service until it is repaired to the original manufacturer's standards.

Repairs

All repairs shall be made by qualified personnel in conformance with Presto's instructions.

Operators

Only trained personnel and authorized personnel shall be permitted to operate lift.

Before Operation

Before using the device, the operator shall have:

- Read and/or had explained, and understood, the manufacturer's operating instructions and safety rules.
- Inspected the device for proper operation and condition. Any suspect item shall be carefully examined and a determination made by a qualified person as to whether it constitutes a hazard. All items not in conformance with Presto's specification shall be corrected before further use of the lift.

During Operation

The device shall only be used in accordance with this owner's manual.

- Do not overload.
- Ensure that all safety devices are operational and in place.

Modifications or Alterations

Modifications or alterations to any Presto industrial positioning equipment shall be made only with written permission from Presto.

SAFETY ALERT SYMBOLS AND SIGNAL WORDS

The safety of all persons operating, maintaining, repairing, or in the vicinity of this equipment is of paramount concern. This is a powerful machine with moving parts, and is capable of causing personal injury if proper precautions are not taken. Therefore, throughout this manual, certain hazards have been identified which may occur in the use of the machine, and there are appropriate instructions or precautions which should be taken to avoid these hazards. In some cases, there are consequences which may occur if instructions or precautions are not followed. Below are the symbols and signal words along with their definitions referenced from ANSI Z535.4 - Product Safety Signs and Labels.

Safety Alert Symbols

These are the safety alert symbols.. They are used to alert you to potential physical injury hazards. Obey all safety messages that follow this symbol to avoid possible injury or death.



For use with **DANGER** signal word
(Red Background)



For use with **WARNING** signal word
(Orange Background)



For use with **CAUTION** signal word
(Yellow Background)

Signal Words

The meaning of different signal words as defined by ANSI Standard Z535.4 indicates the relative seriousness of the hazardous situation.



(Red Background)

DANGER indicates a hazardous situation which, if not avoided, will result in death or serious injury.



(Orange Background)

WARNING indicates a hazardous situation which, if not avoided, could result in death or serious injury.



(Yellow Background)

CAUTION, used with the safety alert symbol, indicates a hazardous situation which, if not avoided, could result in minor or moderate injury.



(Blue Background)

NOTICE is used to address practices not related to personal injury.



(Green Background)

SAFETY INSTRUCTIONS (or equivalent) signs indicate safety-related instructions or procedures.

SECTION 2

SAFETY

The battery-operated stackers are very powerful lifts capable of doing large amounts of work.

DO NOT INSTALL OR OPERATE THESE LIFTS WITHOUT CAREFULLY READING THIS MANUAL. In order to provide for the safe operation of these stackers, Presto Lifts has identified certain hazards that may occur during the installation, maintenance and use of these lifts. For safety reasons these units are designed to be serviced or repaired in the collapsed position. If performed properly, this will greatly reduce the possibility of injury.

⚠WARNING

- Do not perform any repair work on lifts if there is a load on the forks or platform.
- Do not perform any repair work if the forks or platform is in the raised position.
- All personnel must stand clear of the lift while in motion.
- Do not put hands or feet under the forks or platform.
- Do not stand underneath the forks or platform.
- Do not stand in front of the stacker while in motion.
- Do not stand, sit or climb on the lift.
- Do not use the lift on soft, uneven or unstable surfaces.
- Do not exceed the load center or capacity.

SECTION 3

INSTALLATION

A. INSPECTION:

Upon receipt of the stacker, inspect the equipment completely to determine if there is any shipping damage, and that the lift is complete. Presto Lifts tests and inspects every piece of equipment prior to shipment. If damage is apparent, a freight claim must be filed with the freight company. Do not use the lift if there appears to be any damage. With the lift in a collapsed position, check the following:

- Check for signs of damage especially to the back cabinet that houses the battery, electrical/hydraulic power pack.

- Check all connections for tightness. Is there hydraulic fluid visible?
- Check base frame for dimensions and structural integrity.
- Inspect for any bent or damaged metal parts.

B: REMOVING FROM PALLET

Each of the Presto stackers is shipped out on a pallet or skid. Prior to removing the unit from the pallet or skid, remove all tie down straps and packaging. Visually inspect the unit as closely as possible.

With an overhead hoist or forklift, carefully pick up the lift taking into consideration the center of gravity of the unit. If you choose to pick the unit with an overhead hoist, use a nylon sling and hoist with a minimum of 2,000-lb. capacity. The nylon sling will not do any damage to the steel construction of stacker. Pick the unit up by the top cross member of the lift. Be careful of the stacker swinging once fully lifted off the pallet or skid. Have all personnel completely cleared from the area.

Pick the unit up approximately six inches above the pallet or skid. Once raised, remove the pallet or skid from below the lift. Do not move the lift around in the air once secured in the raised position, remove the pallet from below and place the stacker on the ground.

SECTION 4

OPERATION

A. OPERATING INSTRUCTIONS:

1. To raise lift, push control handle.
2. To lower lift, pull control handle.
3. Whenever the control handle is released, the lift stops.

AUTHORIZED OPERATORS SHOULD READ AND UNDERSTAND ALL INSTRUCTIONS, PRECAUTIONS AND WARNINGS.

IMPROPER USE OF THIS LIFT TRUCK COULD RESULT IN INJURY AND/OR DAMAGE TO LOAD AND EQUIPMENT.

- Inspect the lift for damaged or worn parts.
- *Do not* use if not in safe operating condition.
- Use lift on hard level surfaces only.
- Make sure load is evenly distributed, not loose or unstable, and is as far back on platform or forks as

possible. *Do not* pick up loads on tips or forks or edge of platform.

- For fork models, adjust forks to the maximum practical width. Pick up loads on both forks.
- *Do not* overload. Check load center and load weight capacities on manufacturer's nameplate.
- Make sure travel and work area is clear of obstructions.
- Check overhead clearance before lifting loads or transporting.
- Make sure floor lock pad is in firm contact with floor before lifting load, lowering load or using as a workstation.
- Brace or block lift when sliding loads on or off platform or forks.

B. DAILY OPERATIONS MAINTENANCE CHECKS:

1. Battery (If Equipped)

- A. Check for corroded and loose terminals. A white powder substance will be present if there is any existing corrosion.
- B. Visually inspect for any cracks or damage to the casing.
- C. Check for loose battery tie-downs.

2. Charger (If Equipped)

- A. Inspect wire connections.
- B. Check power cord for nicks/damage.
- C. Check charger for proper mounting.

Hydraulic System

- D. Inspect pump and cylinder for oil leaks.
- E. Check hydraulic oil level.
- F. Check hydraulic fittings and hoses.
- G. Check ram for nicks/damage.
- H. Check fluid level. Unscrew plug or cap on reservoir with the forks or platform in the lowered position. The fluid will be 1/2 to 3/4 of an inch from the opening.

3. Frame Assembly

- A. Check floor lock.
- B. Check placement of safety screen.
- C. Check chain roller assembly connections.
- D. Check for any worn or damaged parts.

SECTION 5

BATTERY MAINTENANCE

A. PREPARING TO CHARGE A BATTERY

1. Always turn off E-stop and key switch before working with the batteries.
2. Be sure the area around the stacker and the battery is well ventilated while battery is being charged.
3. The battery terminals, connections and wiring connections should be clean and free of corrosion. When cleaning any of these components wear a face shield or other suitable protective eyewear.
4. For a sealed battery (a battery without cell caps) carefully follow the manufacturer's recharging instructions that are provided with the battery. If you do not have a copy of these instructions or the instructions for the battery charger they are available free of charge by calling Presto @ 1-800-343-9322.
5. Read, understand and follow all battery and battery charger manufacturer's specific precautions while working with and/or charging batteries.

B. LOCATING THE CHARGER

1. Locate charger as far away from battery as the cables permit.
2. Do not operate charger in a closed area or restrict ventilation in any way.

C. PRECAUTIONS FOR GROUNDING AND AC POWER CORD CONNECTION

Charger should be grounded to reduce risk of electric shock. Charger is equipped with an electric cord having an equipment-grounding conductor and grounding plug. The plug must be plugged into an outlet that is properly installed and grounded in accordance with all local codes and ordinances.



Never alter the AC cord or plug provided. If it will not fit outlet, have proper outlet installed by a qualified electrician. Improper connection can result in a risk of an electric shock.

D. BATTERY CHARGER CONNECTION PRECAUTIONS



Connect and disconnect the DC output plug (or clips) only when the AC cord is disconnected from the electric outlet. Never allow clips to touch each other.

1. To charge the unit, plug the charger into the 110 volt wall outlet. The charger is pre-wired to the battery.
2. Disconnect the charger from the 110 volt wall outlet once the indicators read fully charged.

SECTION 6 MAINTENANCE

Operation of Presto Hydraulic Lifts is very simple — as is their construction and require very little maintenance. Reasonable care will result in excellent trouble-free performance. Presto Hydraulic Lifts are designed for one-man operation and ease of performance.

A. INSTRUCTIONS:

- ↑ Grease wheels and casters at least once a month to maintain easy roll of lift.
- ↑ Use only Hydraulic Oil (Conoco Super Hydraulic 32) in the hydraulic system. See hydraulic oil specifications table on page 25.
- ↑ *Do not* overload your lift.

B. MONTHLY OPERATIONS MAINTENANCE CHECKS:

1. Battery

- A. Clean terminals.
- B. Clean battery compartment area.
- C. Check specific gravity — fully charged battery should read 1265. Using a hydrometer that measures specific gravity can check this.

2. Hydraulic System

- A. Clean and inspect hydraulic cylinder.
- B. Lubricate chain with a rust inhibitive lubricant.
- C. Check chain tension. The chain should be tight enough so that it does not come off of the roller assembly.

3. Frame Assembly

- A. Clean and lubricate all roller bearings and cam followers.
- B. Clean and inspect all welds.
- C. Check wheels for wear and damage.
- D. Inspect nameplate for legibility. Place the serial and model number shown on the nameplate on the cover of the manual for future reference.

4. Adjust Straddle Stacker Legs

- A. Secure the stacker with an overhead crane or fork truck allowing the weight to be removed from the stacker legs.
- B. Loosen the adjustment bolts and adjust both legs equally to the desired width.
- C. Re-tighten the adjustment bolts.
- D. Test the stacker to ensure proper adjustment.

All adjustments should be done by qualified personnel. If in doubt, please contact your local dealer or Presto Lifts Customer Service Department at 800-343-9322.

SECTION 7

TROUBLESHOOTING

IF LIFT DOES NOT RISE TO FULL HEIGHT — check for leaks or shortage of oil.

Maintain the proper oil level. To check oil level, follow these instructions:

A.) Old style Power Unit (vertical)

- On left hand side, on top of oil well, you will find a hexagon cap screw which is also a dipstick.
- Remove the cap screw and fill oil well with hydraulic oil. Oil should reach notch on dipstick.

B.) New style Power Unit (horizontal)

- Unscrew the fill plug located on the top of the reservoir. The oil level will be 1-2 inches down from the top. If the oil level is down, fluid can be added at this point.

IF THE LIFT TENDS TO CREEP DOWNWARD UNDER A LOAD — a speck of dirt may be obstructing the seating of the valve and allowing leakage.

To correct, follow these instructions:

- Raise lift to full lifting height and then lower it to lowest point of lift. It may be necessary to do this five or six times. In lowering the lift, lower it in stages, that is, lower the lift six inches to a foot at a time. This will dislodge the dirt and lift will operate properly.

**FIGURE 1:
CHAIN ROLLER ASSEMBLIES**

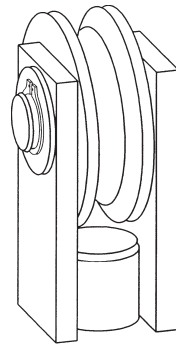

**P/N: 0584-VR
(single chain roller)**

P/N: 0585-VR

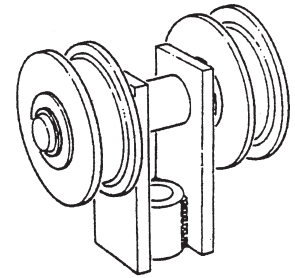

P/N: C105A-TVR

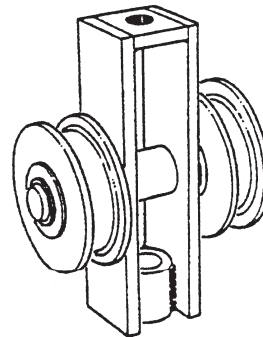

**P/N: C105-BVR 62" 2700#
C105-CVR 74" 2700#**

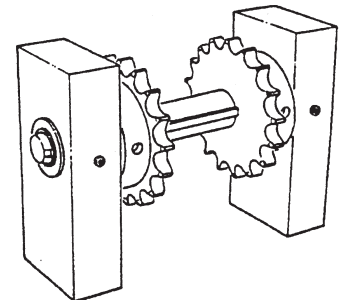

P/N: C105-B-TVR

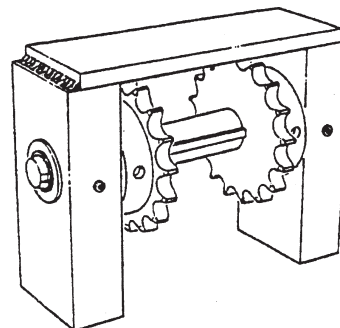
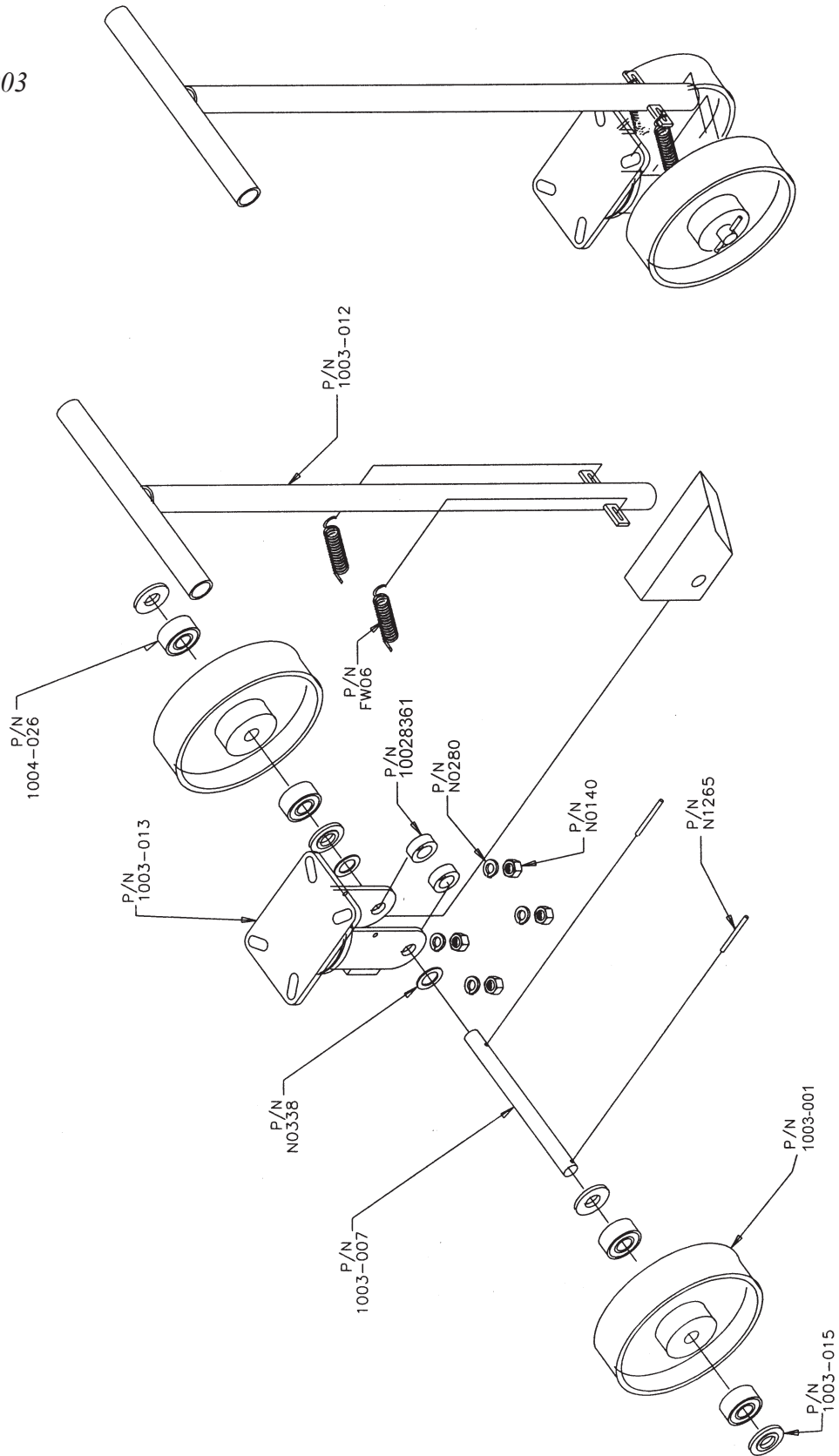

FIGURE 2A:
5TH WHEEL ASSEMBLY
BREAKDOWN
P/N: 1003-016VR

*This assembly
 used prior to June 2003*



NOTE: For old machines that had a single wheel 5th wheel assembly, a replacement wheel is no longer available. The machine would need to be converted to our current design which would require (1) 1003-014-02 adapter trunnion and (1) 1003-016VR new style 5th wheel assembly. New mounting holes may need to be drilled.

FIGURE 2B:
5TH WHEEL ASSEMBLY WITH TRUNNION
P/N: 80000624VR

Used from June 3, 2004 on.

Item	Description	Qty	P/N
1	ACP 5TH WHEEL ASSEMBLY	1	1003-016VR
2	ACP TRUNNION WM 5TH WHEEL	1	80000966VR
3	HA SCREW HHCS .50-13 X 1.50	4	N1050
4	BK-HA WSHR LCK-SPT STL .5	4	N0280
5	BK-HA NUT HEX STL .50-13	4	N0160
6	BK-HA SCREW HHCS .37-16 X 1.00	4	N0920
7	BK-HA WASHER LCK-SPT STL .37	4	N0260

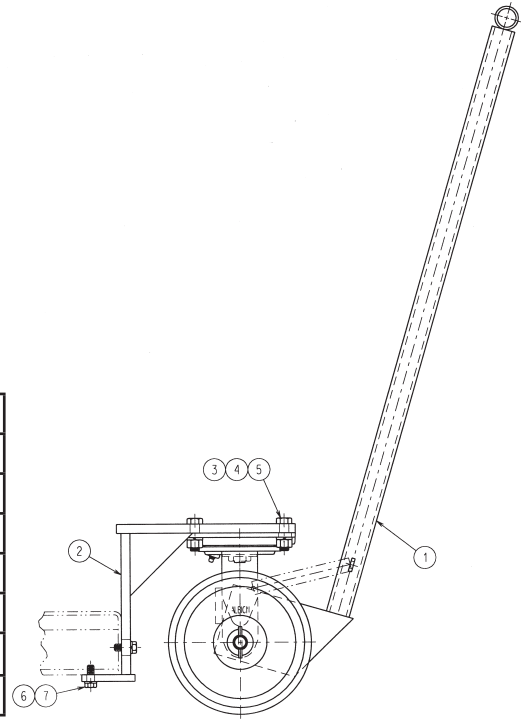

FIGURE 2C:
5TH WHEEL ASSEMBLY ONLY
P/N: 1003-016VR

Used from June 3, 2004 on.

Item	Description	Qty	P/N
1	5TH WHEEL HANDLE	1	80000693
2	CASTER ASSEMBLY	1	1003-013
3	WHEEL	2	30001082
4	PIN	1	30001083
5	SPACER	2	10029103
6	WASHER	6	30001085
7			
8	ROLL PIN	2	N1265
9	SPRING	2	FW06

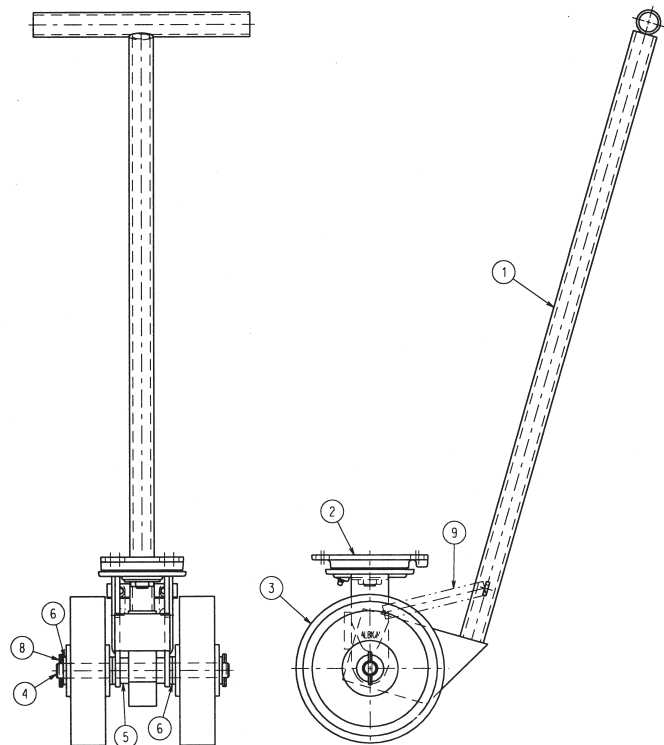
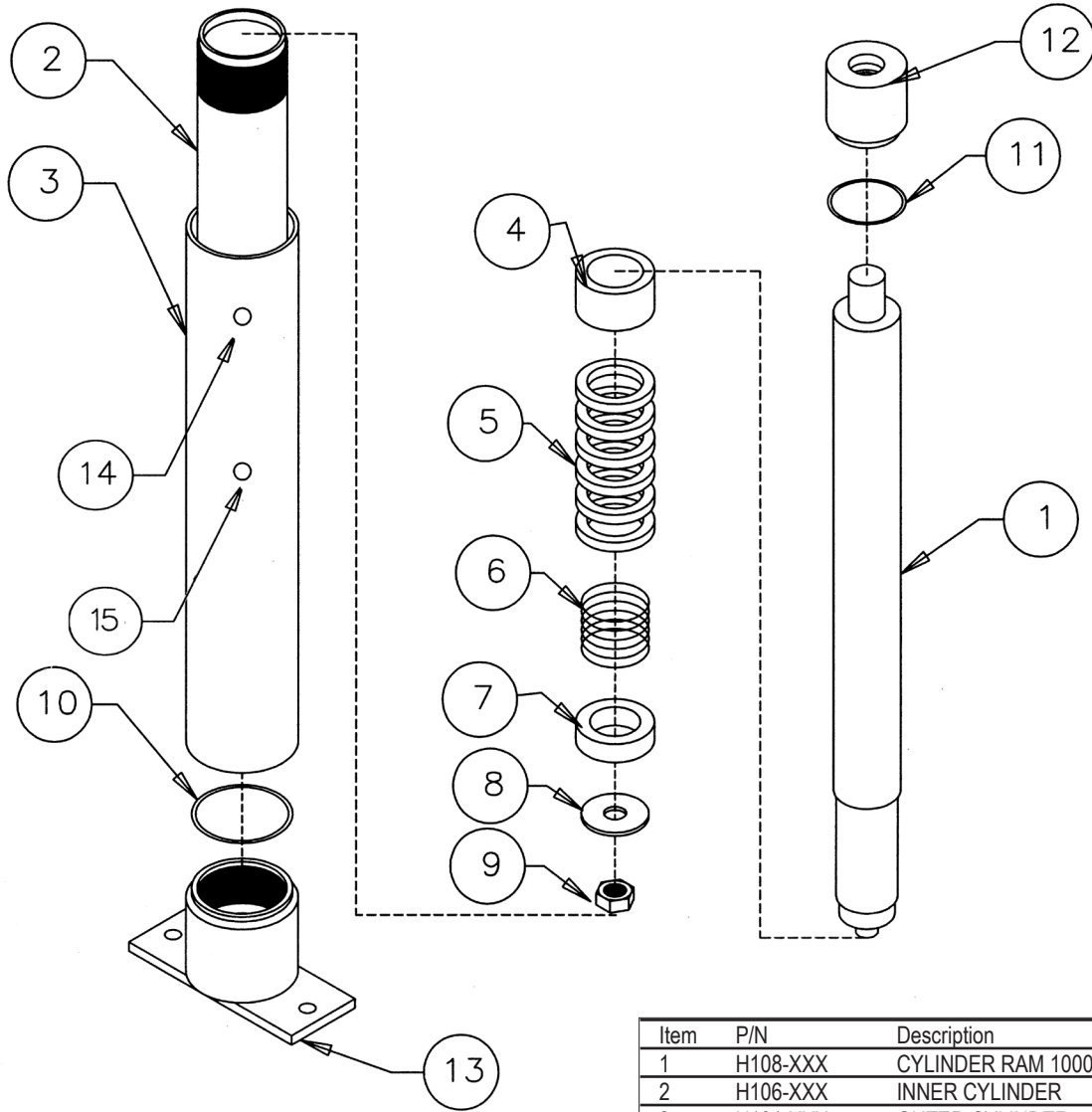

FIGURE 3A: 78" Lift Height or Less

*If cylinder barrel #3 connects to the base #13 with an O-Ring joint (only a seam will be visible) use seal kit H100KVR.
Seal kit P/N H100KVR includes items 4 thru 12.*



Item	P/N	Description	Qty.
1	H108-XXX	CYLINDER RAM 1000#	1
2	H106-XXX	INNER CYLINDER	1
3	H101-XXX	OUTER CYLINDER	1
4	H108A	BEARING CHEVRON SUPPORT	1
5	H109	CHEVRON SET	1
6	H111	SPRING CHEVRON	1
7	H112	RAM GUIDE	1
8	H113-2000	WASHER RAM GUIDE	1
9	N0130	NUT RAM GUIDE	1
10	H107A	O'RING CYL. BASE	1
11	H104-1000	O'RING RAM SEAL	1
12	H105-1000	CAP CYLINDER	1
13	H107-1000-1	BASE CYLINDER	1
14	H102-2000	1/4" NPT-1/4" Push 90° Elbow-Poly Flo	1
15	N1210	1/4" NPT Plug	1

FIGURE 3B: All lift heights

If cylinder barrel #2 connects to the base #3 with a threaded connection (threads will be visible) use seal kit H100-2000KVR.

Seal kit P/N H100-2000KVR includes items 4 thru 12 & 15.

XXX = lifting height

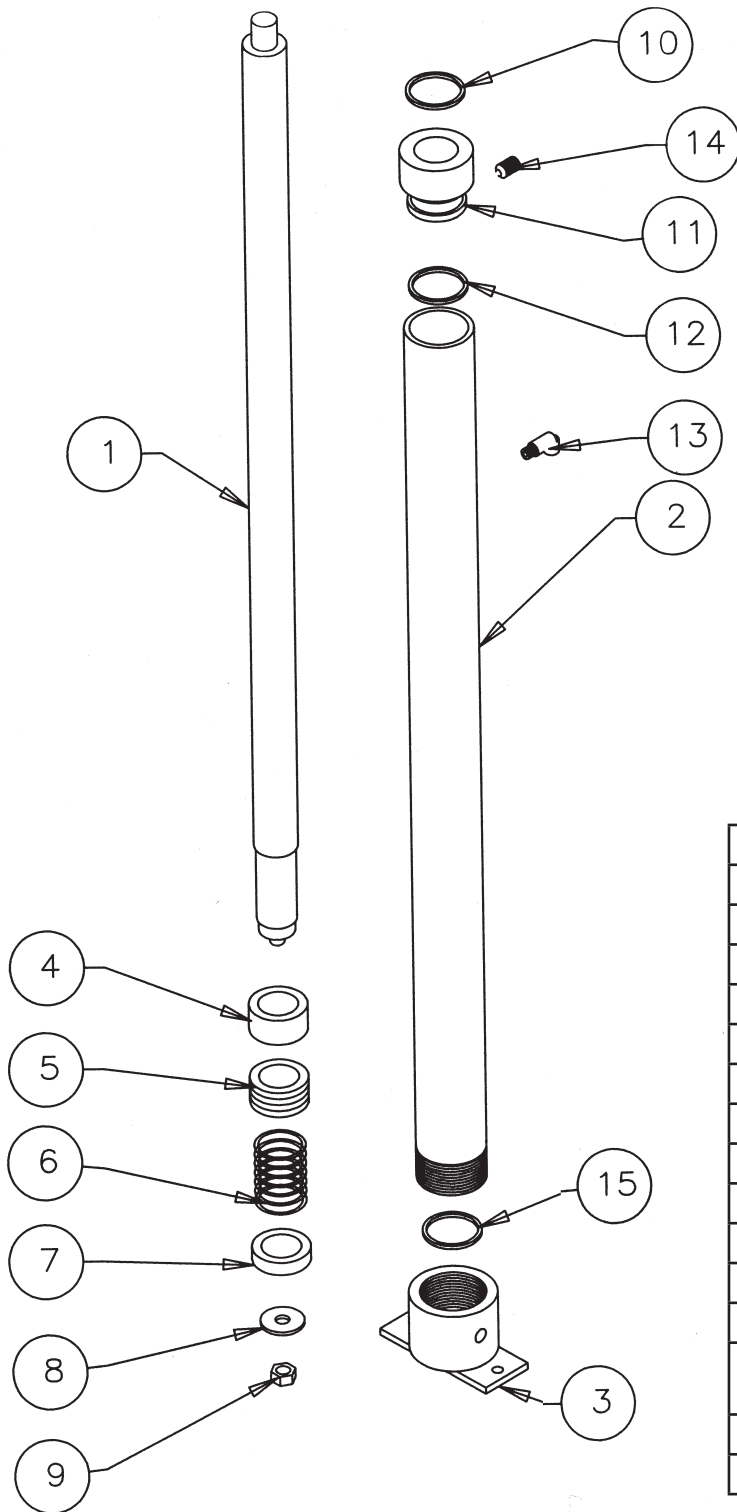

Item	P/N	Description	Qty
1	H108-XXX	Cylinder Ram 2000#	1
2	H106-XXX	Inner Cylinder	1
3	H107-2000	Base Cylinder	1
4	H108A-2000	Bearing Chevron Support	1
5	H109-2000	Chevron Set	1
6	H111-2000	Chevron Spring	1
7	H112-2000	Ram Guide	1
8	H113-2000	Washer Ram Guide	1
9	N0130	Nut Ram Guide	1
10	H104-2000	O-Ring Upper Cap	1
11	H105-2000	Cylinder Cap	1
12	H105-2000A	O-Ring Lower Cap	1
13	H102-2000	Fitting - 1/8" NPT-1/4" Push 90 elbow-poly F10	1
14	M411	Set Screw	2
15	H107-2000A	O-Ring, Cylinder Base	1

FIGURE 3C: 2,000 lb. Capacity Cylinder
 (all AC lifts and all 2 piston hand pump lifts)

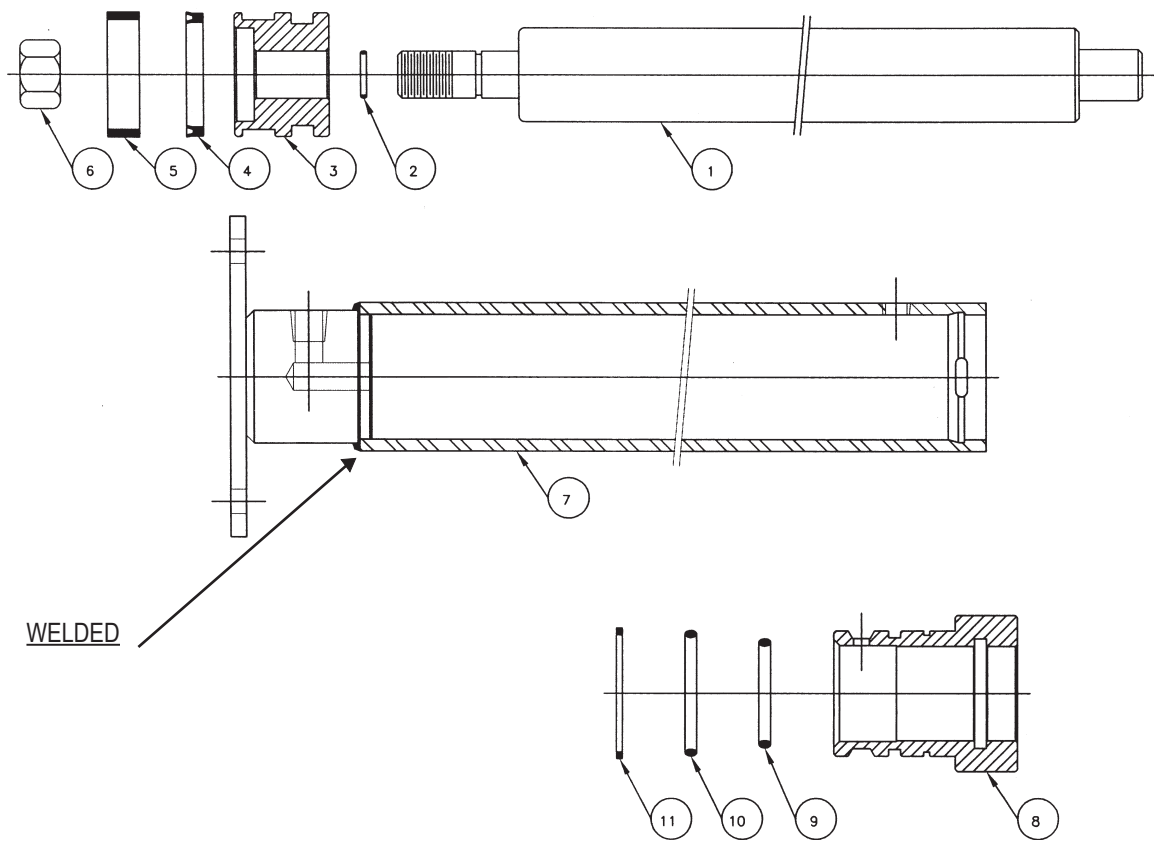

ITEM	DESCRIPTION	QTY
1	SHAFT	1
2	O-RING	1*
3	PISTON	1
4	PISTON SEAL	1*
5	WEAR RING	1*
6	3/4 - 16 HEX NUT	1
7	TUBE WELDMENT	1
8	GLAND	1
9	O-RING	1*
10	O-RING	1*
11	LOCKING WIRE	1

* Items are in seal kit 80000867

FIGURE 4: DC Power Wiring Schematic

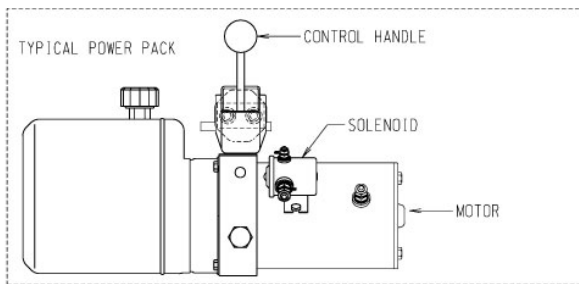
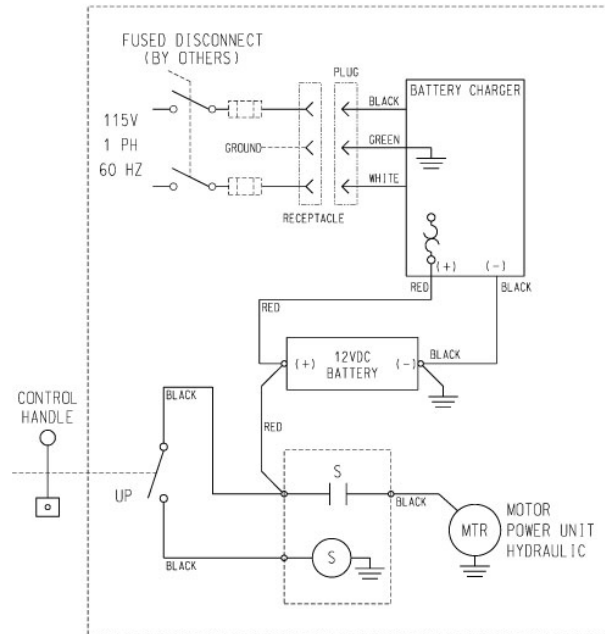
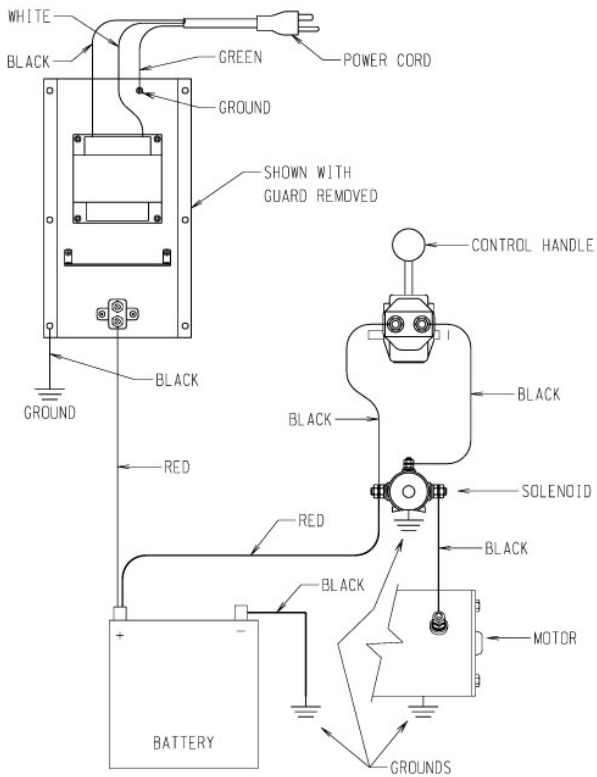

**FIGURE 5:
Old Style DC Power Pack**

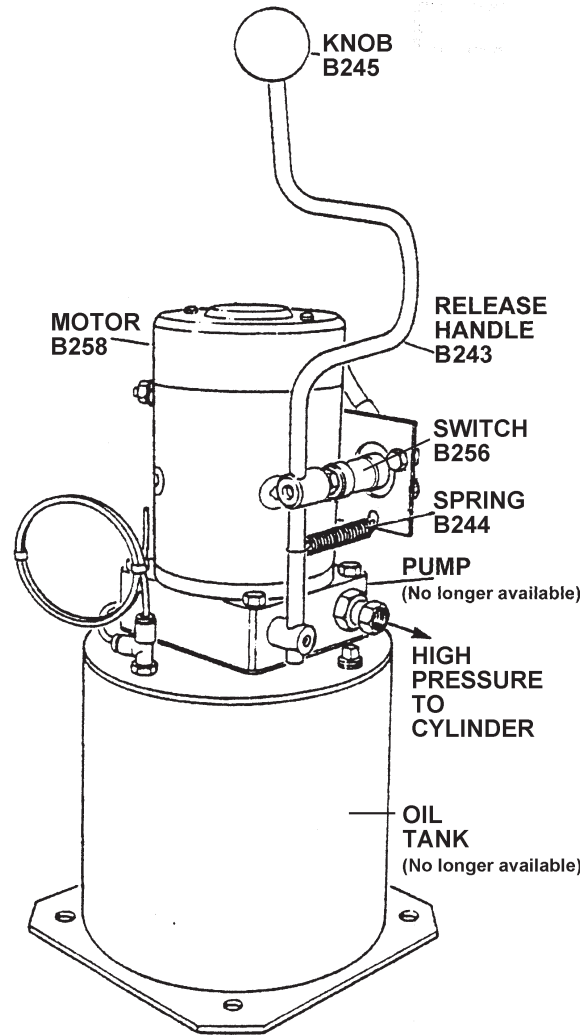

**FIGURE 6: Old Style DC
Power w/ Remote Control**

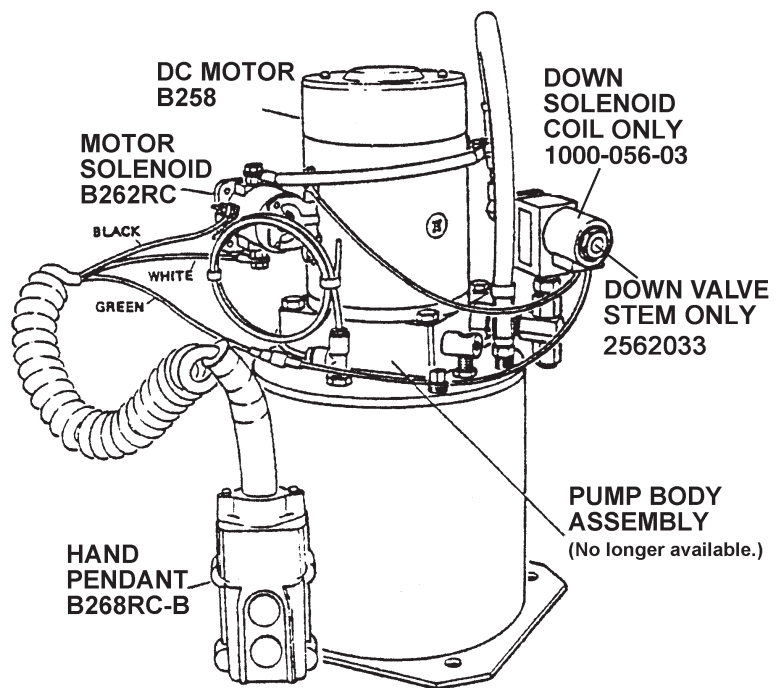
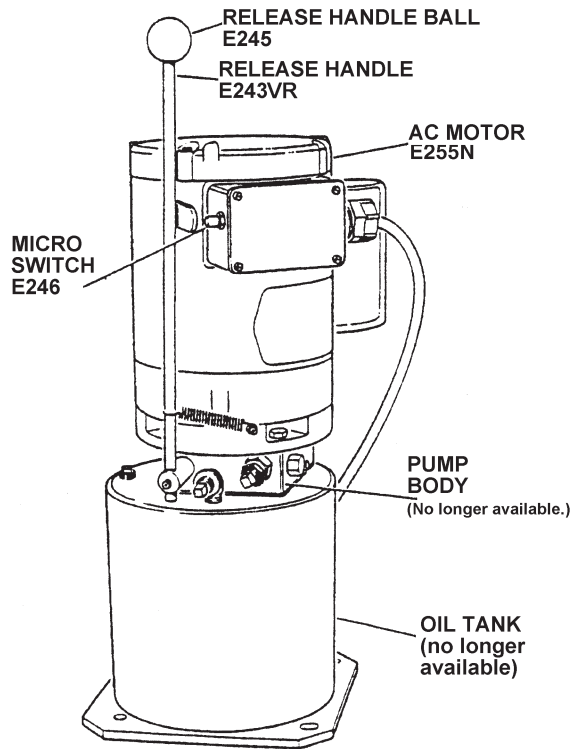

FIGURE 7: Old Style Standard AC Power Pack



**FIGURE 8:
Old Style AC Power with
Remote Control**

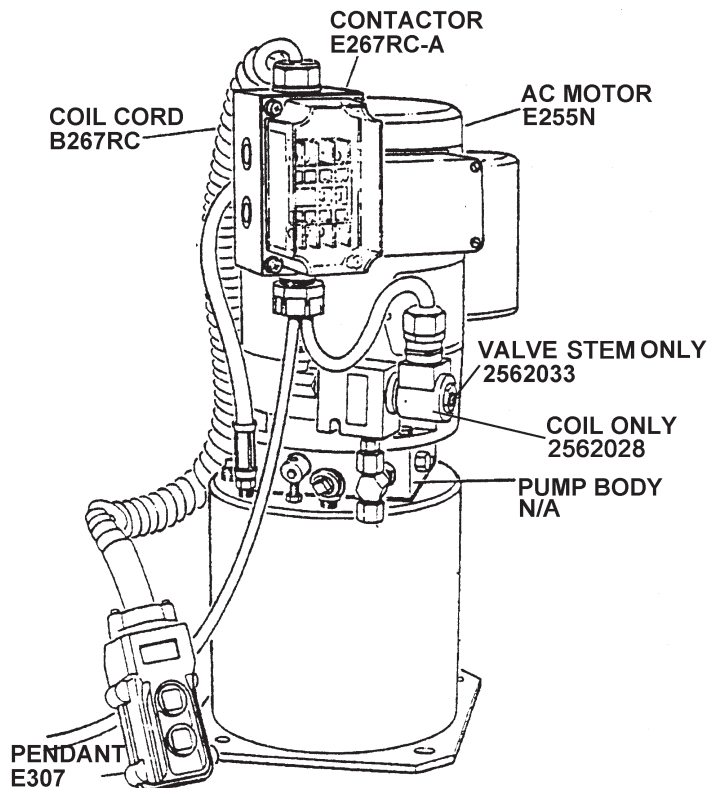

FIGURE 9: DC Wiring Schematic w/ Remote Control

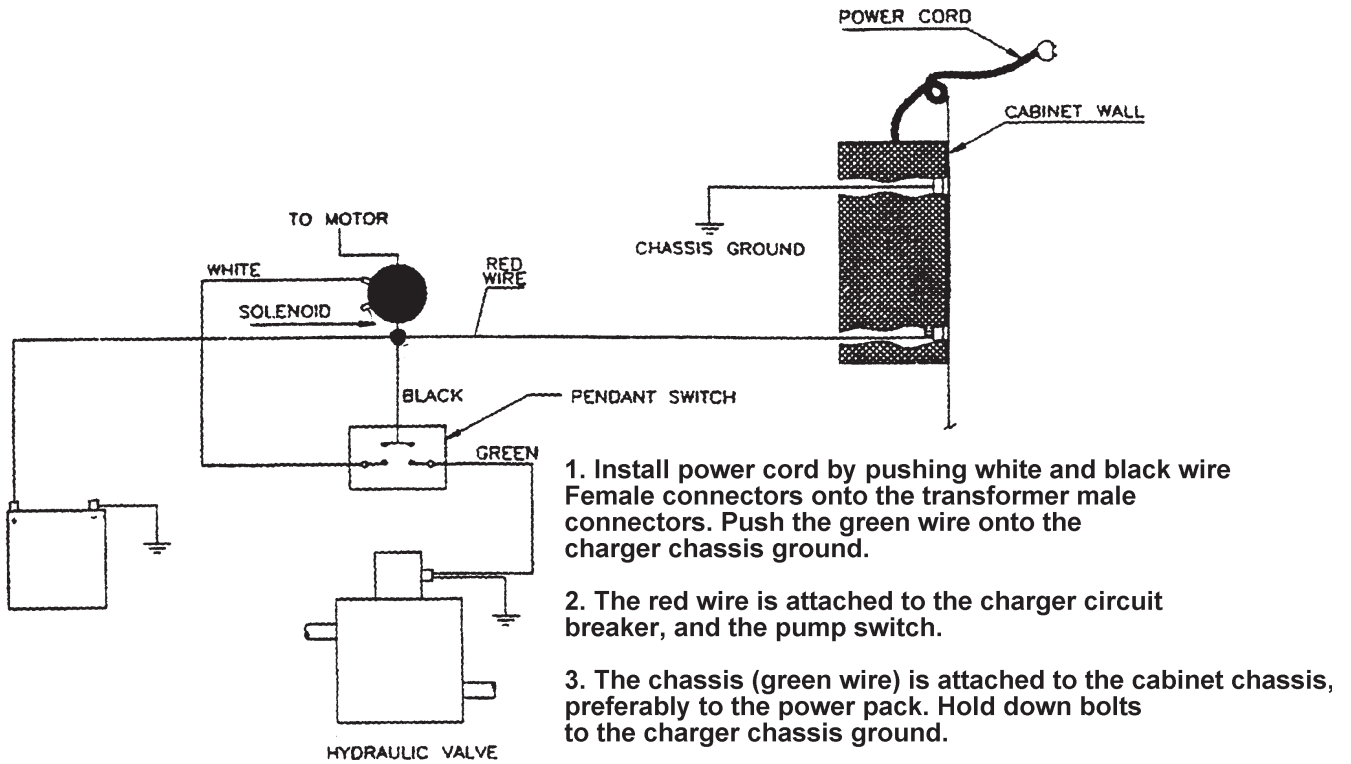

FIGURE 10A: AC Wiring Schematic w/ Remote Control

NOTE:
 - ENTRY LOCATIONS MAY DIFFER FROM THOSE SHOWN.
 - GROUND CONNECTIONS, ARE REQUIRED.

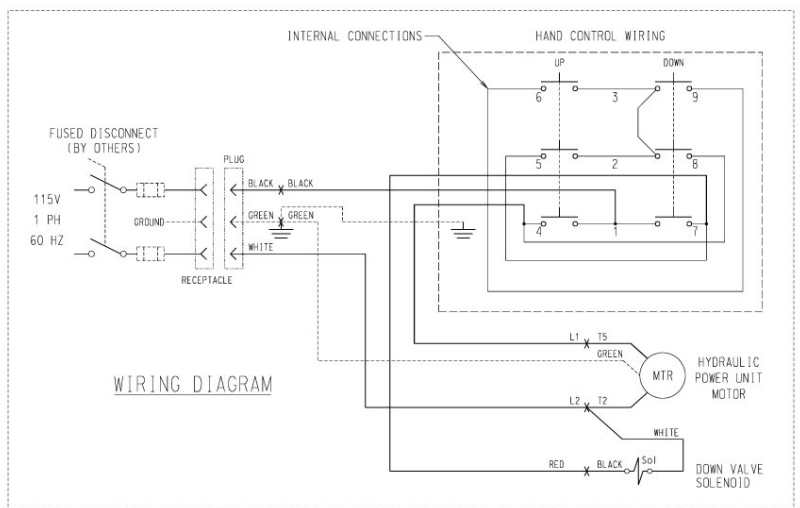
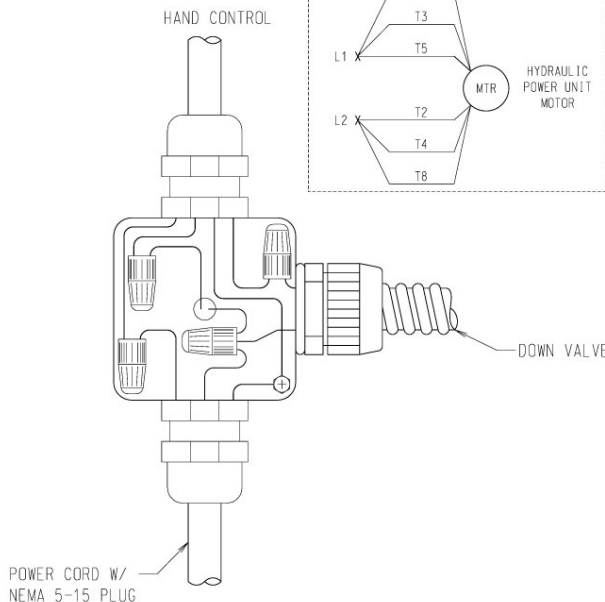
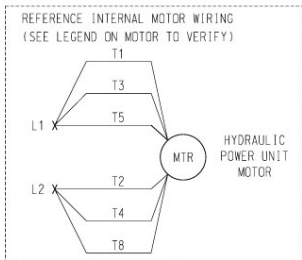
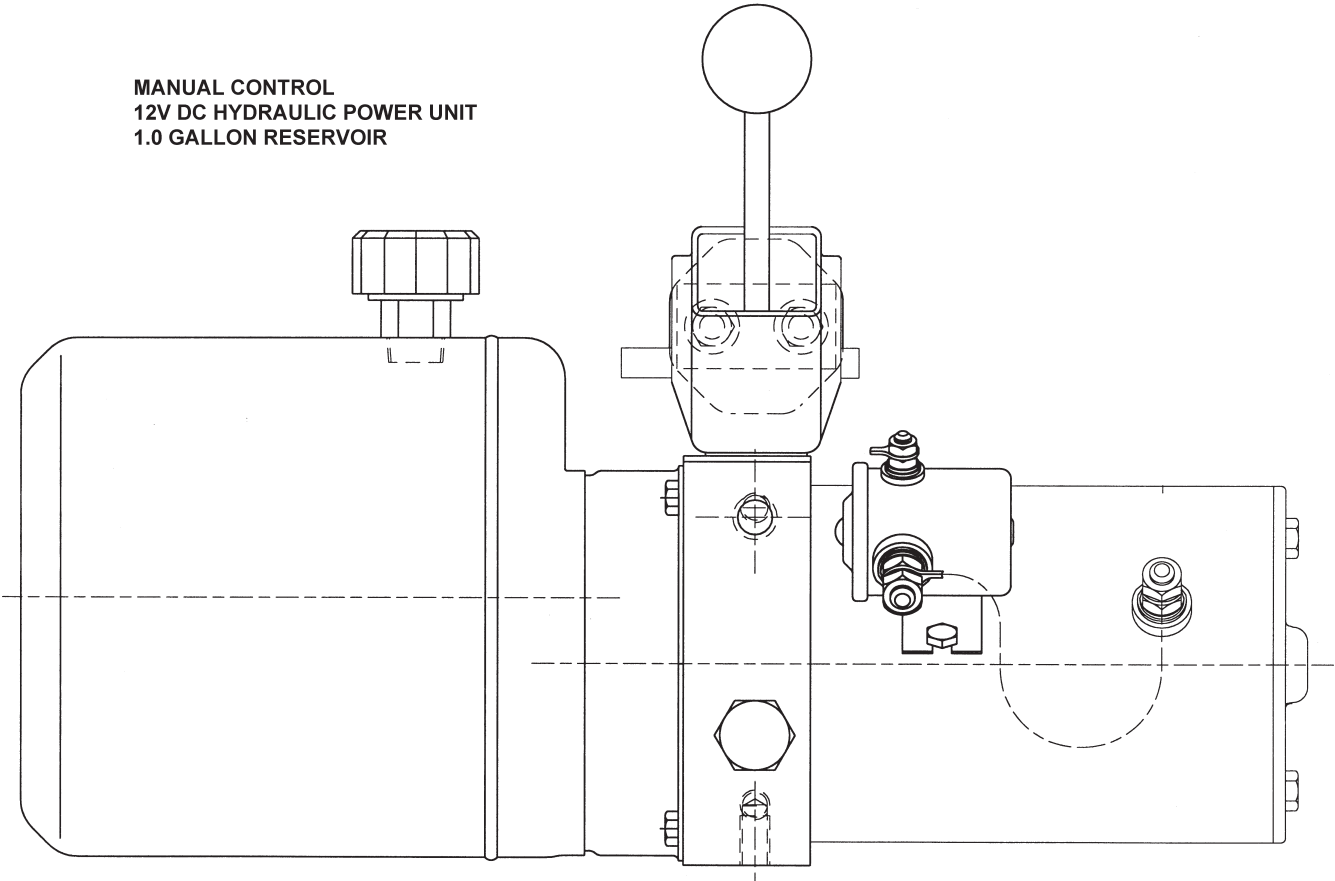

FIGURE 10B: New Style DC Power Pack for stackers



**MANUAL CONTROL
12V DC HYDRAULIC POWER UNIT
1.0 GALLON RESERVOIR**

Call the Presto Parts department to determine available parts for the new style power unit. Have the model and serial number of the lift available.

FIGURE 10C:

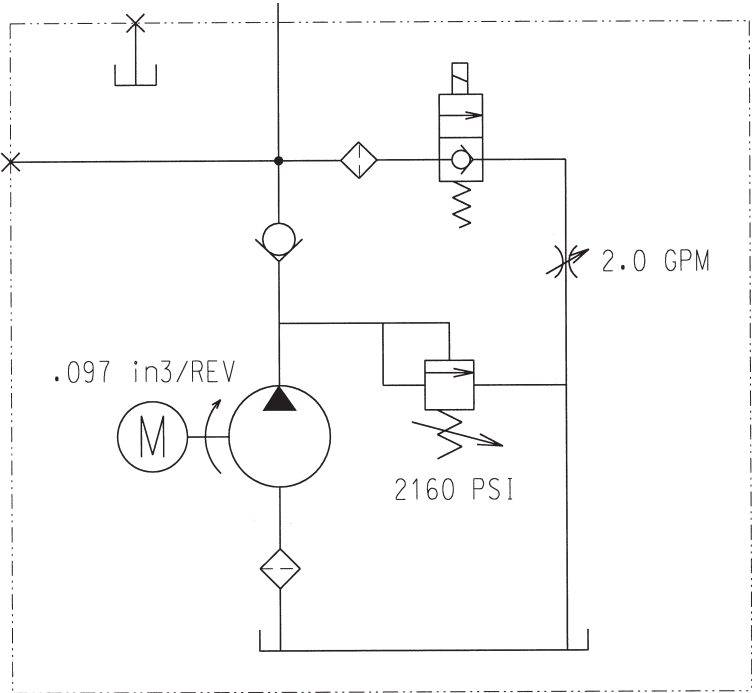
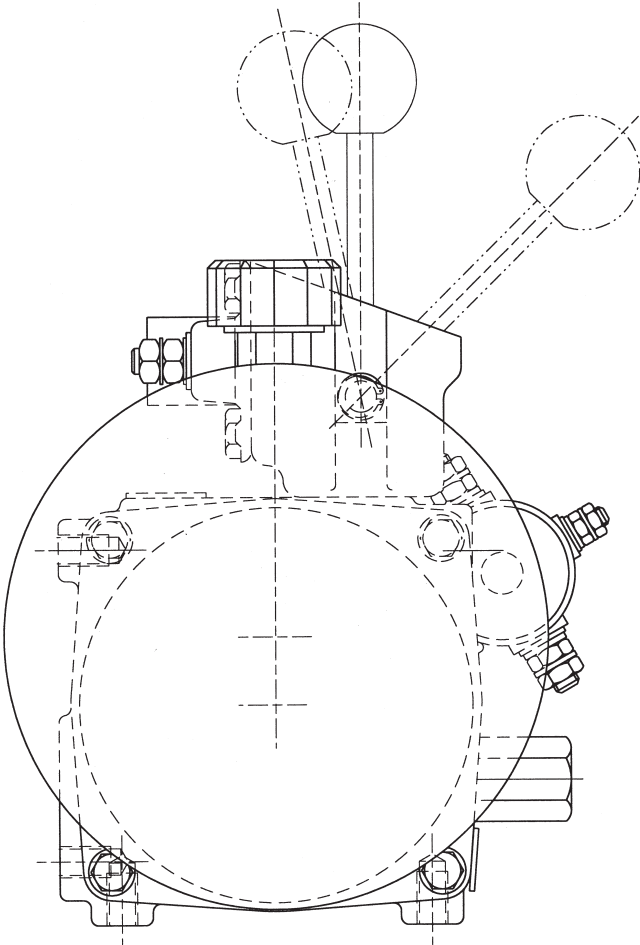

HYDRAULIC SCHEMATIC

FIGURE 11: Generic Floor Lock Assembly

Floor Lock Assembly Detail	
Item No.	Description
1	PSL23 – Lock Assy. Bracket
2	PSL29 – Collar, Shaft
3	0491-XX – Handle, Lock
4	PSL25 – Lever, Lock
5	PSL28 – Pin, Lock Lever
6	N0810 – Bolt, Handle Lock
7	N0040 – Nut, Handle Lock
8	M437 – Pad, Lock
9	PSL21ABC – Holder, Lock Pad
10	PSL26 – Spring, Lock Return
11	PSL24 – Mount, Lock
12	PSL22 – Stud, Adjustable
13	2340772 – Nut, Adjustable

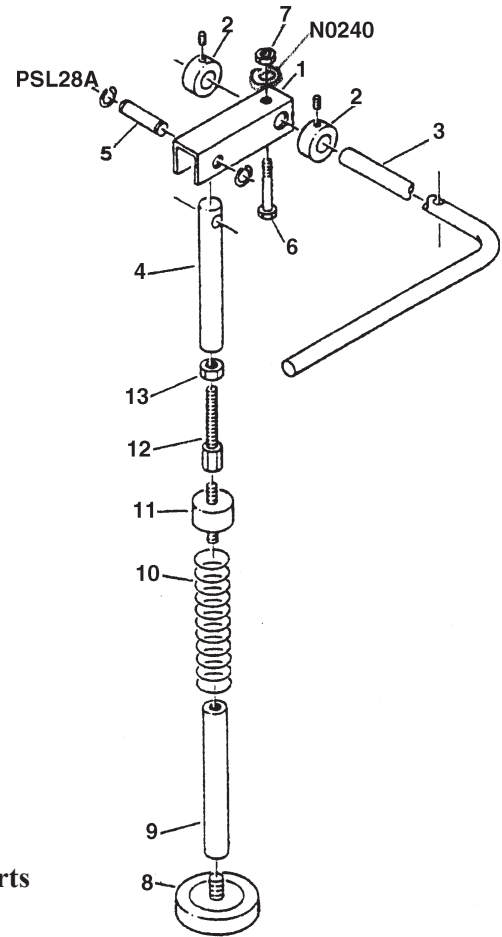

NOTE: Model and Serial Number Required When Ordering Parts

FIGURE 12: Bearing Bracket Assembly-
For B, EPF, & ESF models only. For all other models, contact
Parts Department.

Bracket Assembly Detail

Item No.	Description
1	Bracket – Left (C111VR)
2	Bracket – Right (C112VR)
3	Hood Bearing (C107)
4	Hood Bearing, Nut (2340772)
5	Lock Washer (N0300)
6	Internal Lock Washer (N0427)
7	Spacer (C108)
8	Bearing Plate Bolt (N0920)
9	Plate Lock Washer (N0261)
10	Side Thrust Bearing (C114)
11	Bolt, Side Thrust (N0961)
12	Lock Washer (N0260)

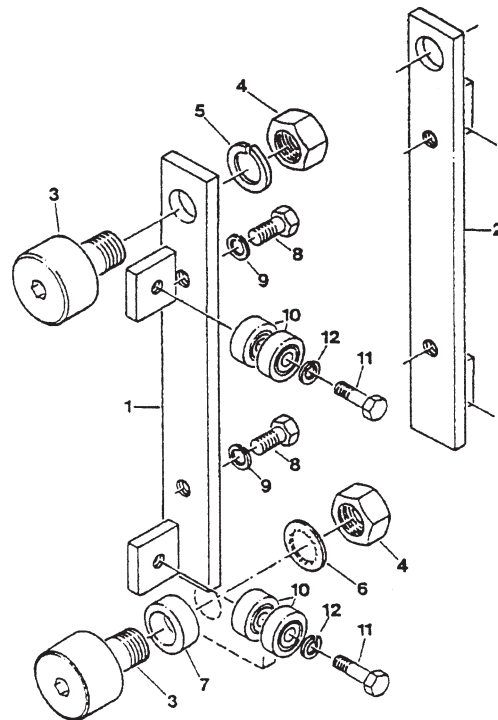

FIGURE 13: Pallet Straddle Stacker

Component Identification	
Item No.	Description
1	Chain Roller Assembly
2	Adjustable Forks
3	Phenolic Wheels
4	Hydraulic Cylinder
5	Flow Control Valve
6	Floor Lock Handle
7	Bearing Bracket Assembly

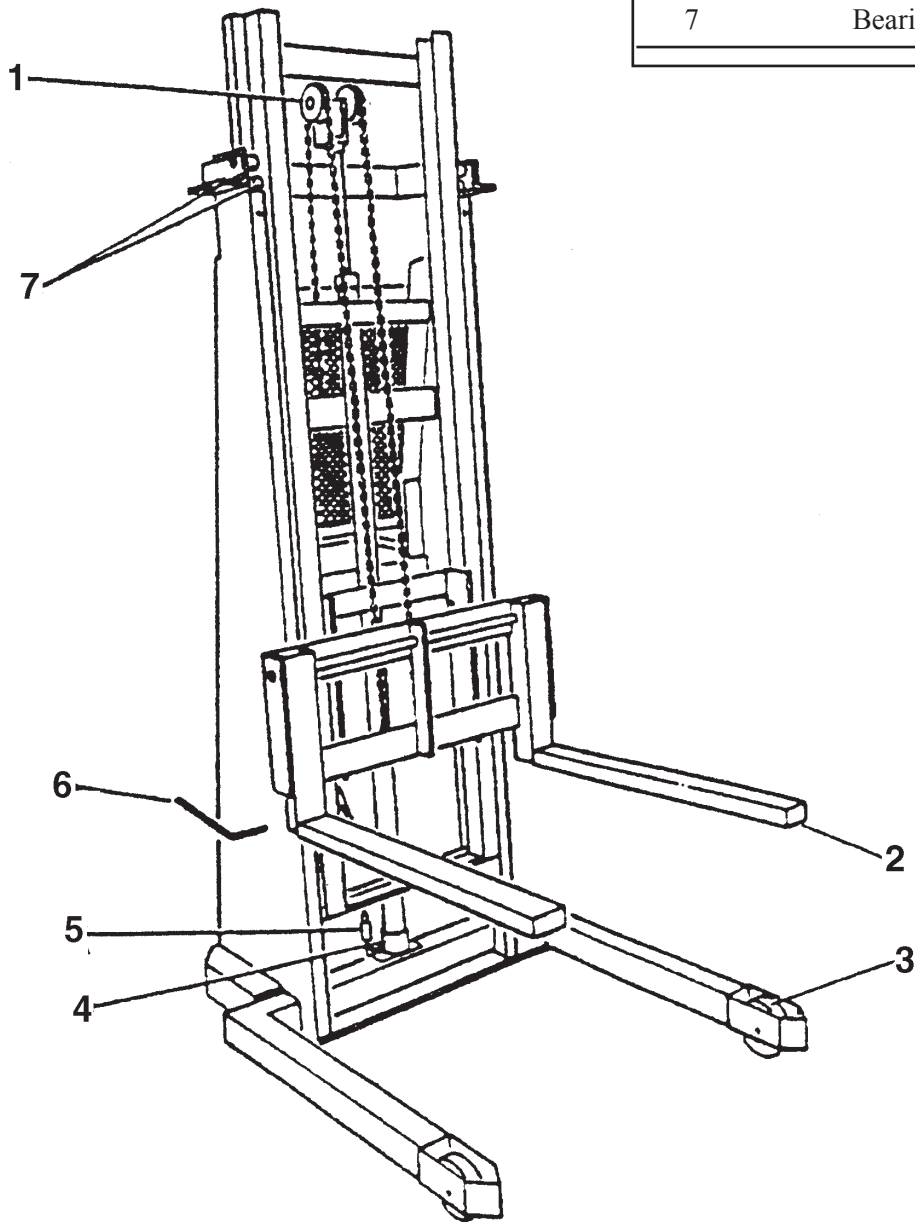
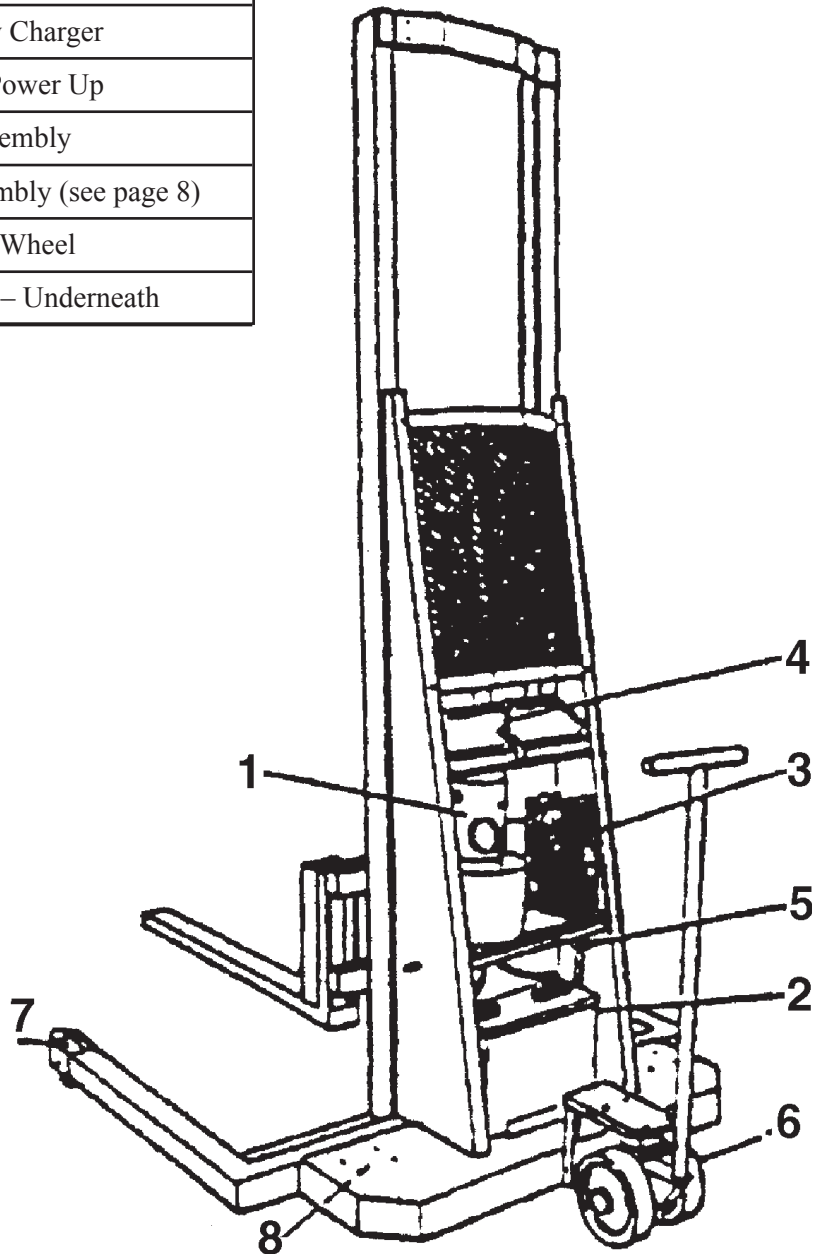

FIGURE 14: Pallet Straddle Stacker

Component Identification

Item No.	Description
1	DC Power Pack
2	12 volt Battery
3	Internal Battery Charger
4	Hand Lever – Power Up
5	Floor Lock Assembly
6	5 th Wheel Assembly (see page 8)
7	Rigid Phenolic Wheel
8	Swivel Wheels – Underneath



RECOMMENDED SPARE PARTS LISTING

* = Old Style Power Units (see Figure 6, 7, 9 & 10) ** = Old Style Cylinder kits (see Figure 3A & 3B)

Description	Part Number	Used On: Model
Flow Control Valve	B211RC-A	All units
Adjustable Flow Control Valve	2533004	Optional Purchase
Release Handle	* B243	All Units (Standard DC power)
Release Handle Connecting Pin	* B243C	All Units
Release Handle Spring	* B244	All Units
Release Handle Plastic Knob	* B245	All Units
Battery Cable – Ground	B246	All Units
Battery Cable – Positive	B247	All Units
Battery Charger – 10 AMP	Call Presto	All B Series, C and D Series
Battery Charger – 15 AMP	Call Presto	All P Series
Oldham Coupling	* B255	All Units
Switch	* B256	All Units
Motor to Switch connector	* B257A	All Units
DC Motor – 12 volt	* B258	All 1000 & 1500 lb. capacities
Solenoid For DC Hand Pendant	* B262RC	All Units w/ Remote Controls
Solenoid Coil Only	* 2562028	115VAC Units
Solenoid Valve – Down DC	* B263RC-01	All Units w/ Remote Controls
Solenoid Valve w/ Coil – DC Down	* B263RC	All Units w/ Remote Controls
Hand Pendant for 12 volt power packs	B268RC-B	All Units w/ Remote Controls
Floor Locks	C100	All B5, B6, B7, E, D and C Series
Floor Lock Adapters	C100AVR	All B5, B6, B7, E, D and C Series
5th Wheel Assembly – Complete	1003-016VR	All P Series and Optional B Series
Swivel Caster Assembly w/4x2 steel wheel	10044712	Optional
Swivel Caster Assembly w/ 4x2 rubber wheel	C101R2	Optional
Swivel Caster Assembly w/4x2 poly wheel	30001353	Optional
Swivel Caster Assembly w/4x2 phenolic wheel	C101PH2	Standard - Check Equipment
Swivel Caster Assembly w/5x2 steel wheel	C101S5	Optional
Swivel Caster Assembly w/ 5x2 rubber wheel	C101-R5	Optional
Swivel Caster Assembly w/5x2 poly wheel	C101P5	Optional
Swivel Caster Assembly w/5x2 phenolic wheel	C101PH5	Standard - Check Equipment
5x2 Steel Wheel Only For Swivel Caster Assembly	C102S	Optional
5x2 Phenolic Wheel Only For Swivel Caster Assembly	C102PH	Optional
5x2 Rubber Wheel Only For Swivel Caster Assembly	C102R	Optional
5x2 Poly Wheel Only for Swivel Caster Assembly	C102P	Optional
Wheel Shaft With Washer	C103	All Units
Cylinder Seal Kits (1,000 lb. capacity units)	**H100KVR	All 1,000 lb. capacity units
Cylinder Seal Kits (2,000 lb. capacity units)	**H100-2000KVR	All 1500, 2000 and 2700 lb. cap.
4x1.5 Rubber with Swivel Caster	C101R	

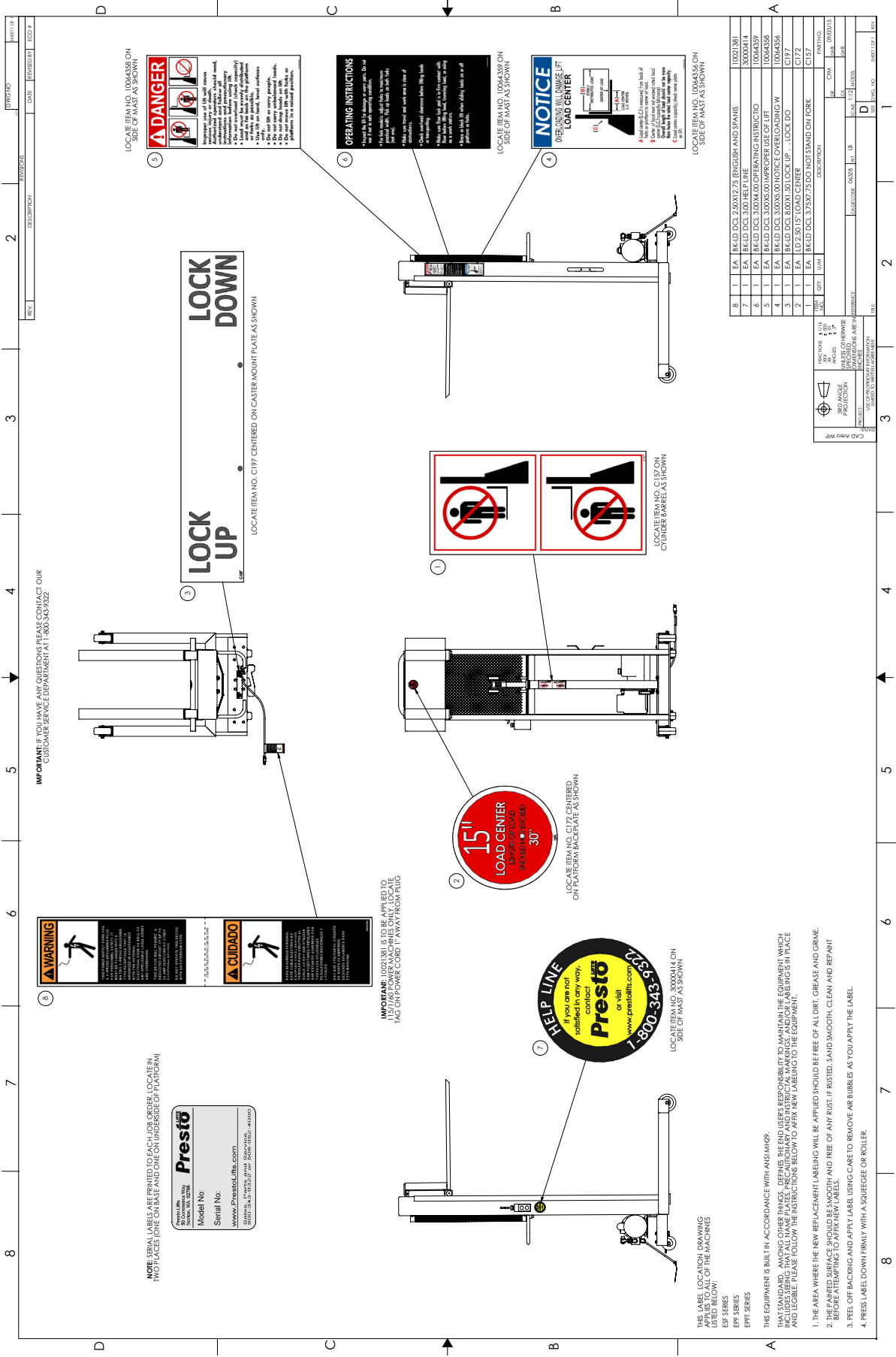

REV	DESCRIPTION	DATE	APPROVED	EDD

IMPORTANT: IF YOU HAVE ANY QUESTIONS PLEASE CONTACT OUR CUSTOMER SERVICE DEPARTMENT AT 1-800-348-9322

NOTE: SERIAL LABELS ARE PRINTED TO EACH LOS (LOS OPERATOR LOCATIONS) TWO PLACES (ONE ON BASE AND ONE ON UNDERSIDE OF PLATFORM)

THIS LABEL LOCATION DRAWING APPLIES TO ALL OF THE MACHINES LISTED BELOW:

- EPF SERIES
- EPFT SERIES

THIS EQUIPMENT IS BUILT IN ACCORDANCE WITH ANSI/ISO THAT STANDARD. AMONG OTHER THINGS, DEFINES THE END USER'S RESPONSIBILITY TO MAINTAIN THE EQUIPMENT WHICH IS THE USER'S RESPONSIBILITY TO MAINTAIN. THE USER MUST FOLLOW THE INSTRUCTIONS BELOW TO ATFX NEW LABELING AND LEGIBLE PLEASE FOLLOW THE INSTRUCTIONS BELOW TO ATFX NEW LABELING TO THE EQUIPMENT.

1. THE AREA WHERE THE NEW REPLACEMENT LABELING WILL BE APPLIED SHOULD BE FREE OF ALL DIRT, GREASE AND GRIME.
2. THE PAINTED SURFACE SHOULD BE SMOOTH AND FREE OF ANY RUST, IF RUSTED, SAND SMOOTH, CLEAN AND REPAINT BEFORE ATTEMPTING TO ATFX NEW LABELS.
3. PEEL OFF BACKING AND APPLY LABEL USING CARE TO REMOVE AIR BUBBLES AS YOU APPLY THE LABEL.
4. PRESS LABEL DOWN FIRMLY WITH A SQUEEGEE OR ROLLER.

LOCATE ITEM NO. 10064556 ON SIDE OF MAST AS SHOWN

LOCATE ITEM NO. 10064556 ON SIDE OF MAST AS SHOWN

LOCATE ITEM NO. 10064556 ON SIDE OF MAST AS SHOWN

LOCATE ITEM NO. 10064556 ON SIDE OF MAST AS SHOWN

LOCATE ITEM NO. 10064556 ON SIDE OF MAST AS SHOWN

LOCATE ITEM NO. 10064556 ON SIDE OF MAST AS SHOWN

LOCATE ITEM NO. 10064556 ON SIDE OF MAST AS SHOWN

LOCATE ITEM NO. 10064556 ON SIDE OF MAST AS SHOWN

LOCATE ITEM NO. 10064556 ON SIDE OF MAST AS SHOWN

LOCATE ITEM NO. 10064556 ON SIDE OF MAST AS SHOWN

LOCATE ITEM NO. 10064556 ON SIDE OF MAST AS SHOWN

LOCATE ITEM NO. 10064556 ON SIDE OF MAST AS SHOWN

LOCATE ITEM NO. 10064556 ON SIDE OF MAST AS SHOWN

LOCATE ITEM NO. 10064556 ON SIDE OF MAST AS SHOWN

LOCATE ITEM NO. 10064556 ON SIDE OF MAST AS SHOWN

LOCATE ITEM NO. 10064556 ON SIDE OF MAST AS SHOWN

LOCATE ITEM NO. 10064556 ON SIDE OF MAST AS SHOWN

LOCATE ITEM NO. 10064556 ON SIDE OF MAST AS SHOWN

LOCATE ITEM NO. 10064556 ON SIDE OF MAST AS SHOWN

LOCATE ITEM NO. 10064556 ON SIDE OF MAST AS SHOWN

LOCATE ITEM NO. 10064556 ON SIDE OF MAST AS SHOWN

LOCATE ITEM NO. 10064556 ON SIDE OF MAST AS SHOWN

LOCATE ITEM NO. 10064556 ON SIDE OF MAST AS SHOWN

8	1	EA	BK-LD DCL 2.50X12.75 (ENGLISH AND SPANIS	10021381
7	1	EA	BK-LD DCL 3.00 HELP LINE	3000914
6	1	EA	BK-LD DCL 3.00M4.00 OPERATING INSTRUCTIO	10064559
5	1	EA	BK-LD DCL 3.00M5.00 IMPROPER USE OF LIFT	10064558
4	1	EA	BK-LD DCL 3.00M5.00 NOTICE COVERLOADING W	10064556
3	1	EA	BK-LD DCL 3.00M1.50 LOCK UP - LOCK DO	C1977
2	1	EA	BK-LD DCL 3.00M1.50 LOCK UP - LOCK DO	C1977
1	1	EA	BK-LD DCL 3.00M1.75 DO NOT STAND ON FORK	C152

INSTRUC	4	1	EA	10021381
DO	4	1	EA	3000914
3RD ANGE	4	1	EA	10064559
PROTECTOR	4	1	EA	10064558
USE OF ANCHOR	4	1	EA	10064556
PLATE	4	1	EA	C1977
PLATE	4	1	EA	C1977
PLATE	4	1	EA	C152

MANUFACT	4	1	EA	10021381
OR	4	1	EA	3000914
3RD ANGE	4	1	EA	10064559
PROTECTOR	4	1	EA	10064558
USE OF ANCHOR	4	1	EA	10064556
PLATE	4	1	EA	C1977
PLATE	4	1	EA	C1977
PLATE	4	1	EA	C152

INSTRUC	4	1	EA	10021381
DO	4	1	EA	3000914
3RD ANGE	4	1	EA	10064559
PROTECTOR	4	1	EA	10064558
USE OF ANCHOR	4	1	EA	10064556
PLATE	4	1	EA	C1977
PLATE	4	1	EA	C1977
PLATE	4	1	EA	C152

INSTRUC	4	1	EA	10021381
DO	4	1	EA	3000914
3RD ANGE	4	1	EA	10064559
PROTECTOR	4	1	EA	10064558
USE OF ANCHOR	4	1	EA	10064556
PLATE	4	1	EA	C1977
PLATE	4	1	EA	C1977
PLATE	4	1	EA	C152

INSTRUC	4	1	EA	10021381
DO	4	1	EA	3000914
3RD ANGE	4	1	EA	10064559
PROTECTOR	4	1	EA	10064558
USE OF ANCHOR	4	1	EA	10064556
PLATE	4	1	EA	C1977
PLATE	4	1	EA	C1977
PLATE	4	1	EA	C152

INSTRUC	4	1	EA	10021381
DO	4	1	EA	3000914
3RD ANGE	4	1	EA	10064559
PROTECTOR	4	1	EA	10064558
USE OF ANCHOR	4	1	EA	10064556
PLATE	4	1	EA	C1977
PLATE	4	1	EA	C1977
PLATE	4	1	EA	C152

INSTRUC	4	1	EA	10021381
DO	4	1	EA	3000914
3RD ANGE	4	1	EA	10064559
PROTECTOR	4	1	EA	10064558
USE OF ANCHOR	4	1	EA	10064556
PLATE	4	1	EA	C1977
PLATE	4	1	EA	C1977
PLATE	4	1	EA	C152

INSTRUC	4	1	EA	10021381
DO	4	1	EA	3000914
3RD ANGE	4	1	EA	10064559
PROTECTOR	4	1	EA	10064558
USE OF ANCHOR	4	1	EA	10064556
PLATE	4	1	EA	C1977
PLATE	4	1	EA	C1977
PLATE	4	1	EA	C152

Figure 15: Labels and Locations

Table 1 – Hydraulic Oil Specifications

If the lift will be used at normal ambient temperatures, Presto Lifts supplies the unit with Conoco Super Hydraulic 32 oil. This may be replaced by any other good quality oil with 150 SSU at 100° F and rust and oxidation inhibitors and anti-wear properties.

If the lift will be used at ambient temperatures below 0°F, use aircraft hydraulic oil. Use Type 15 aircraft hydraulic oil.

The following are equivalent to Conoco Super Hydraulic 32:

TYPE	MANUFACTURER
AW32	CITGO
DTE 24	EXXON/MOBIL
NUTO H32	EXXON/MOBIL
AMOCO AW32	CHEVRON (AMOCO CO.)

CAUTION!

It is very important to keep the hydraulic oil free of dirt, dust, metal chips, water, and other contamination. Most of the problems with hydraulic systems are caused by contamination in the oil.

Ordering Replacement Parts

Presto Lifts has carefully chosen the components in your unit to be the best available for the purpose. Replacement parts should be identical to the original equipment. Presto Lifts will not be responsible for equipment failures resulting from the use of incorrect replacement parts or from unauthorized modifications to the unit.

Presto Lifts can supply all replacement parts for your lift. With your order, please include the model number and the serial number of the unit. You can find these numbers on the name plate. This plate is located within the cabinet, or on the angle iron cylinder cross support.

To order replacement parts, please call the Presto Parts Department. Parts are shipped subject to the following terms:

- FOB factory
- Returns only with the approval of our parts department.
- Credit cards preferred (except parts covered by warranty).
- Freight collect for truck (except parts covered by warranty).
- Freight – prepaid and invoice for small parcel shipments (except parts covered by warranty).
- The warranty for repair parts is 30 days from date of shipment.

Parts replaced under warranty are on a “charge-credit” basis. We will invoice you when we ship the replacement part, then credit you when you return the worn or damaged part, and we verify that it is covered by our warranty. Labor is not covered under warranty for Parts orders.

Presto Parts Department
50 Commerce Way, Norton, MA 02766
Telephone: 800-343-9322 • FAX: 888-788-6496
Email: service@PrestoLifts.com
www.PrestoLifts.com

PARTS

Standard parts may be returned with a 20% restocking fee or \$35.00 net, whichever is greater. Modified or custom-engineered parts are not returnable. Unfortunately, due to potentially concealed damage, all sales of electrical assemblies are final.

QUALITY ISSUES

Should you feel there is a quality problem, please contact the seller to ask questions and gather information on how to rectify the issue. Presto Lift Inc. reserves the right to determine potential credits, as a result of factory defects, based on its inspection of the merchandise.

GENERAL

All products shipped from our factory have passed Quality Assurance inspection and testing. The carrier of choice has signed for, and accepted the product in new working condition. The customer should inspect to ensure it is not received damaged, has no concealed damage or is not incomplete. Parts orders are determined to be complete based upon Presto Lift, Inc. inspection sheets and carrier shipping weights.

RETURN MATERIALS AUTHORIZATION POLICY

Presto Lifts provides the Return Materials Authorization (RMA) Policy, for specific models, as a courtesy to our distributors in the event they do not receive what they ordered. If a customer wishes to return a Presto Lifts product, please contact the Customer Service Department and request an RMA number. This request must be made on or before the fifteenth calendar day following the date of Presto Lifts' invoice for the merchandise. Not all units are returnable. Quantity orders and special designs cannot be returned under any circumstances. Presto Customer Service reserves the right for final judgment on all product returns.

The RMA number must appear on the outside of any packaging material for a return to be accepted and processed by Presto Lifts. Customers shipping returns from the Continental US, Canada, or Mexico have thirty (30) days from date of RMA issue to have the product arrive at Presto Lifts' facility. All merchandise must arrive Free on Board at Presto Lifts' facility or the shipment will be refused and returned to the sender. All credits are issued less restocking and refurbishing charges, regardless if the merchandise was damaged in transit.

Return addresses: please refer to your RMA for the address to which your product should be returned.

Presto Lift Inc.
715 Highway 77
Manila, Arkansas 72442

Telephone: 800-343-9322
Fax: 888-788-6496

MANY NEEDS REQUIRE MANY OPTIONS...

Presto LIFTS



LET PRESTO MEET THOSE NEEDS!

Call Presto Sales
for stock or
customized lift inquiries:
800-343-9322

Email: sales@prestolifts.com

