

## Presto XL, P3PH Series and ECOA HLT Series Scissor Lifts



### Installation, Operation and Service Manual

Model Number \_\_\_\_\_

Serial # \_\_\_\_\_

Date placed in service \_\_\_\_\_

**IMPORTANT: READ CAREFULLY  
BEFORE INSTALLING OR OPERATING LIFT**

Part orders are subject to a \$50 minimum charge.





**This label (part # 10095524)  
is required by California law.  
For more information visit  
[www.P65Warnings.ca.gov](http://www.P65Warnings.ca.gov).**

# CONTENTS

<b>SECTION 1:</b>	
Introduction.....	4
Responsibility of Owners and Users.....	5
Safety Alert Symbols and Signal Words.....	6
<b>SECTION 2:</b>	
Safety.....	7
<b>SECTION 3:</b>	
Installation.....	8
A. Inspection.....	8
B. Installing.....	8
C. Electricals.....	8
D. Hydraulics.....	9
E. Testing the Lift with No Load.....	9
<b>SECTION 4:</b>	
Operation.....	9
A. Method of Operation.....	9
B. Operating Procedures.....	9
<b>SECTION 5:</b>	
Maintenance.....	10
A. Routine Maintenance.....	13
B. Troubleshooting Maintenance.....	14

## LIST OF FIGURES :

Figure 1. Maintenance Chock.....	11
Figure 2. Pinch Points.....	12
Figure 3. XL Scissor Lifts.....	15
Figure 4. Exposed Cylinder Assembly.....	16
Figure 5. Exposed Power Pack.....	16
Figure 6. HLT - General Description with drawings.....	17
Figure 7. Wiring Schematic 115/1/60 power.....	18
Figure 7A. Wiring Schematic 208,230/1/60 power with 20 AMP Plug.....	18
Figure 8. Wiring Schematic 208, 220, 460/3/60 Power with Pig Tail.....	19
Figure 9. Hydraulic Schematic for all Models.....	20
Figure 10. Labeling Diagram for all Models.....	21
Figure 11. Wiring Diagonal 115 AC no Transformer.....	22
Figure 12. Plumbing Schematic.....	23

## LIST OF TABLES :

Table 1 Hydraulic Oil Specifications.....	23
PARTS/QUALITY ISSUES/GENERAL.....	24
ORDERING REPLACEMENT PARTS.....	25
WARRANTY.....	27

# **SECTION 1**

## **INTRODUCTION**

This manual attempts to provide all of the information necessary for the safe and proper installation, operation and maintenance of XL and HLT Series Scissor Lifts. It is important that all personnel involved with the installation, maintenance or operation of the scissor lift read this manual.

Where unique situations arise, that are not covered in this manual, call Presto-ECO A Lifts for further instructions. Additional manuals are available upon request or on our web site at [www.prestolifts.com](http://www.prestolifts.com).

The scissor lift has a nameplate that provides the load capacity ratings, serial number and model identifications. Please refer to these numbers when ordering parts or requesting further information.

The XL and HLT Series Lifts are designed for lifting, lowering and positioning a variety of loads. WHERE UNIQUE SITUATIONS ARISE, THAT ARE NOT COVERED IN THIS MANUAL, CALL PRESTO-ECO A LIFTS FOR FURTHER INSTRUCTIONS.

The XL and HLT Series are designed for inplant/nonhazardous location use only. These units are not for personnel lifting.

# Responsibility of Owners and Users

## **Inspection and Maintenance**

The device shall be inspected and maintained in proper working order in accordance with Presto-ECO's owner's manual.

## **Removal from Service**

Any device not in safe operating condition such as, but not limited to, excessive leakage, missing rollers, pins, or fasteners, any bent or cracked structural members, cut or frayed electric, hydraulic, or pneumatic lines, damaged or malfunctioning controls or safety devices, etc. shall be removed from service until it is repaired to the original manufacturer's standards.

## **Repairs**

All repairs shall be made by qualified personnel in conformance with Presto's instructions.

## **Operators**

Only trained personnel and authorized personnel shall be permitted to operate these lifts.

## **Before Operation**

Before using the device, the operator shall have:

- Read and/or had explained, and understood, the manufacturer's operating instructions and safety rules.
- Inspected the device for proper operation and condition. Any suspect item shall be carefully examined and a determination made by a qualified person as to whether it constitutes a hazard. All items not in conformance with Presto's specification shall be corrected before further use of these lifts.

## **During Operation**

The device shall only be used in accordance with this owner's manual.

- Do not overload.
- Ensure that all safety devices are operational and in place.

## **Modifications or Alterations**

Modifications or alterations to any Presto-ECO industrial positioning equipment shall be made only with written permission from Presto.

# SAFETY ALERT SYMBOLS AND SIGNAL WORDS

The safety of all persons operating, maintaining, repairing, or in the vicinity of this equipment is of paramount concern. This is a powerful machine with moving parts, and is capable of causing personal injury if proper precautions are not taken. Therefore, throughout this manual, certain hazards have been identified which may occur in the use of the machine, and there are appropriate instructions or precautions which should be taken to avoid these hazards. In some cases, there are consequences which may occur if instructions or precautions are not followed. Below are the symbols and signal words along with their definitions referenced from ANSI Z535.4 - Product Safety Signs and Labels.

**4.11 Safety Alert Symbols:** A symbol that indicates a hazard. It is composed of an equilateral triangle surrounding an exclamation mark. The safety alert symbol is only used on hazard alerting signs. It is not used on safety notice and safety instructions signs.



**A): for use with DANGER signal word;** (safety white triangle, safety red exclamation mark, safety red background)

**B): for use with WARNING signal word;** (safety black triangle, safety orange exclamation mark)

**C): for use with CAUTION signal word;** (safety black triangle, safety yellow exclamation mark)

**D) and E): for use with DANGER, WARNING, or CAUTION signal word;** (D: is a safety yellow triangle with a black border and safety black exclamation mark; E: is a safety yellow triangle with a safety black exclamation mark and a safety yellow border around a safety black band)

NOTE: D and E are provided to allow for consistency with certain ISO standards such as ISO 3864-1 and ISO 3864-2.

**4.14 Signal Words:** The words used in the signal word panel. The signal words for hazard alerting signs are "DANGER," "WARNING," and "CAUTION." Safety notice signs use the signal word "NOTICE." Safety instruction signs use signal words that are specific to the situation.



DANGER indicates a hazardous situation which, if not avoided, will result in death or serious injury.



WARNING indicates a hazardous situation which, if not avoided, could result in death or serious injury.



CAUTION indicates a hazardous situation which, if not avoided, could result in minor or moderate injury.



NOTICE is used to address practices not related to physical injury.

NOTE: DANGER, WARNING or CAUTION should not be considered for property damage accidents unless personal injury risk appropriate to these levels is involved.

## SECTION 2

# SAFETY

The safety of all persons installing, using, servicing, or working near the unit is of paramount concern to Presto-ECO Lifts. The lift is a powerful machine with moving parts, and is **capable of causing personal injury if proper precautions are not taken**. Therefore, throughout this manual, Presto-ECO Lifts have identified certain hazards, which may occur in the use of the unit, and provided appropriate **instructions** or precautions that should be taken to avoid these hazards. In some cases, Presto-ECO Lifts has also pointed out the **consequences** that may occur if Presto-ECO Lifts instructions or precautions are not followed. Presto-ECO Lifts use the following nationally recognized system for identifying the severity of the hazards associated with its products:

**⚠ DANGER** Immediate hazard that will result in severe personal injury or death.

**⚠ WARNING** Hazard or unsafe practice, that could result in severe personal injury or death.

**⚠ CAUTION** Hazard or unsafe practice, that could result in minor personal injury or property damage.

**In the interest of safety, please read the entire manual carefully. You must understand the material in this manual before you install, use, or service the unit. If you have any question about any of the instructions in this manual, please contact Presto-ECO Lifts at 1-800-343-9322.**

### SAFETY INSTRUCTIONS

- Do not perform any repair work on a lift with a load on the platform or with the table in a raised position.
- All personnel must stand clear of the lift when the lift is in motion.
- Do not put hands or feet under lift table.
- Do not perform any repair or maintenance work with the lift in an open position without securing it first with proper maintenance devices.
- Do not stand, sit or climb on the lift at any time.
- Do not use the lift on soft, uneven or unstable surfaces.
- Do not exceed the load capacity rating on the data plate.
- Do not place a load on a moving lift.
- Do not exceed load capacity.
- Place a load in the center of the lift and be sure that the load is secured properly.

# SECTION 3 INSTALLATION

## A. INSPECTION:

Upon receipt of the XL or HLT Series Scissor Lift, inspect the equipment completely to determine if there is any shipping damage, and that the lift is complete. Presto-ECO A tests and inspects every piece of equipment prior to shipment. If damage is apparent, a freight claim must be filed with the freight company. Do Not use the lift if there appears to be any damage. With the lift in a collapsed position, check the following:

- Check for signs of damage especially to the electrical and hydraulic components.
- Check all connections for tightness. Is there hydraulic fluid visible?
- Check base frame for flatness.
- Inspect for any bent or damaged metal parts.

## B: INSTALLING

Before starting, be sure that the electrical system is wired and is in full compliance with local electrical codes and ordinances. Read all of the instructions prior to starting the lift.

### Floor Installation

- a) Make sure that the floor in the installation area is level, stable and free from dirt and surface defects.
- b) Place lift in exact operating position.

**⚠ CAUTION**

**When moving the lift, do not ever attempt to pick it up by the platform. The lift should be picked up by the base frame only. The use of a strap sling is suggested. If the lift has optional lifting eyebolts, attach a chain spreader and raise the lift from a center position. Be sure the eyebolts are secured in place with locking nuts prior to lifting.**

- c) Make sure that the complete base of the lift is in contact with the floor. In order to provide complete contact with the floor, the base may be shimmed or grouted.

**⚠ CAUTION**

**Do not spot shim. The complete base must be in contact with the floor or shims.**

- d) If the lift is provided with anchor holes or brackets, be sure the lift has been placed in the exact operating position before spotting or drilling holes for anchor bolts. Bolt the lift securely before using it.

- e) For lifts with remote power units, locate and bolt the power unit in place, so as to provide easy access. Do not obstruct the operator's work area. Make hydraulic connections according to the information contained in Section 3D.

- f) Electrical connections must be made according to the electrical schematics and information contained in Section 3C and in compliance to local codes and ordinances.

### Pit Mounted Installation

- a) Build pit to standard pit dimension as outlined in your pit plan - if supplied, paying careful attention to raceway, sump, clearance and height requirements.

- b) The remaining steps are the same as required for floor installation. See Section 3B (1b to 1f).

**⚠ WARNING**

**Do not install lifts in pits unless they have approved bevel edge top or electro-mechanical toe guards.**

**⚠ CAUTION**

**Lifts with toeguard and oversized platforms must be secured with at least 4 anchor bolts with a minimum of 2000-lb pullout strength for each bolt.**

## C. ELECTRICALS

The motors on XL and HLT Scissor Lifts are special intermittent duty motors with high pull up torques. These motors require heavier duty electrical controls than standard motors.

**⚠ CAUTION**

**All wiring must conform to local codes and must be performed by licensed electricians.**

The following chart recommends power sources for various motors supplied with Scissor Lifts.

MOTOR SIZE	FUSE	BREAKER
1 HP 120 Volt 1 PH	25 AMP	20 AMP
1 HP 240 Volt 1 PH	25 AMP	20 AMP
1-1/2 HP 208-20 Volt 3 PH	15 AMP	10 AMP
1-1/2 HP 460 Volt 3 PH	7-1/2 AMP	5 AMP

**Schematics for wiring motors:**

- Figure 6 for 120 volt 1 PH
- Figure 6 for 240 volt 1 PH
- Figure 7 for 208/240/460 volt 3 PH



## SECTION 4

# OPERATION

### ⚠ WARNING

Do not tamper with or remove cover of the electrical junction box. Only authorized, qualified personnel should service the electrical system.

## D. HYDRAULICS

1. Use hydraulic oil only for the lift. The lift has been supplied with Conoco Super Hydraulic 32.
2. Before using the lift, check the hydraulic oil level and add oil if necessary. Check fittings for tightness. .
3. External power pack units also require that the hydraulic lines be blown out with clean air. Then attach to hydraulic fittings per hydraulic schematic. Figure 8.

### ⚠ CAUTION

**XL and HLT Series Scissor Lifts are designed for normal factory environments. Where below freezing conditions may exist, special fluid must be used. Contact Presto-ECO A for further information when freezing conditions exist.**

### ⚠ WARNING

**Do not use automotive hydraulic, brake or transmission fluids. They will damage seals and pose a serious fire hazard.**

## E. TESTING THE LIFT WITH NO LOAD

1. Before testing the lift, clear the area of any loose material. Be sure the lift has no obstruction above it or on any side. Using the controls provided, briefly operate the lift (5-10 seconds). If the lift begins to rise with a humming sound and functions properly, continue to the full upright position.

### ⚠ CAUTION

**If the lift does not rise immediately, or there is any operational problem, stop it immediately. Before continuing, check the rotation of the pump and motor and the voltage at motor terminals; again briefly operate the lift. If the lift does not move smoothly with a humming sound, stop and review the procedures in the section on troubleshooting (5B).**

2. After raising the lift completely, lower the lift. It should move slowly and smoothly without a humming sound. If the lift operates properly, raise and lower the lift and stop at different levels to get a good perspective on the lift's operations and movements.

## A. METHOD OF OPERATION

All Presto-ECO A Scissor Lifts are provided with a special relief valve and are factory preset for the maximum safe capacity of the lift. Activating and holding the up switch will energize the motor. The motor is attached to a positive displacement pump, that draws hydraulic fluid from the reservoir and transfers it under pressure to the cylinder. This forces the piston forward and the scissor legs to separate and raise the platform, releasing the up button will stop the lift. A check valve between the pump and piston holds the table in position. Depressing and holding the down switch will energize a solenoid, that allows the oil from the cylinder to return to the reservoir through a preset flow control. This allows the lift to lower smoothly and at a controlled speed.

## B. OPERATING INSTRUCTIONS

*In order to operate the lift follow these operating procedures.*

Read and understand all the instructions before operating. If the lift has modifications or accessories, read and understand their functions.

- 1). Load the lift correctly.
  - a). Do not load the lift while it is running.
  - b). Do not exceed the maximum rated load (note that load capacity is reduced due to side or end loading.)
  - c). Place load in the center of table.
  - d). If the load is unstable or may become unstable, fasten it into position.
- 2). Operate the lift.
  - a). To raise the lift, press and hold the up button.
  - b). To lower the lift, press and hold the down button.
  - c). Release the button to stop the lift.
- 3). Wait until the lift has come to a complete stop before unloading the lift.
- 4). Stand clear of lift when operating it in order to avoid injury.

### ⚠ WARNING

- a). **Do not stand, sit or climb onto the lift.**
- b). **Do not load or unload a moving lift.**
- c). **If the lift fails to move or exhibits strange movements or sound, stop immediately. Do not operate the lift until it has been checked and repaired.**
- d). **Obey all warning labels.**

## SECTION 5

# MAINTENANCE

Generally, the XL and HLT Series Scissor Lifts require very little maintenance. Reasonable care will result in excellent trouble-free performance.

### **⚠️ WARNING**

**Never go under or service lift with a load on the table or with the scissor mechanism unblocked. Always service the lift in a down position.**

All servicing should be done by qualified personnel. Qualified personnel should be able to read and understand wiring and hydraulic diagrams. They should be able to troubleshoot live electrical circuits safely and in accordance with accepted practice. **For safety's sake**, if in doubt, please contact your dealer or Presto/ECO A Customer Service Department at (800) 343-9322. Before servicing the lift, read and understand this entire section and the section entitled "Operating Instructions."

## Hazards

There are several hazards you should be aware of as you service the lift:

### **⚠️ DANGER**

The lift may use a power supply of up to 575 Volts AC. This voltage can kill. Do not work with the electrical parts unless you are a qualified electrician!

### **⚠️ WARNING**

- As the lift moves up and down, "pinch points" are formed as shown in Figure 2. Keep hands, feet, and loose clothing away from these pinch points. If your hand or arm or a part of your clothing is caught, you may be hurt.
- A falling lift can cause severe personal injury. Before working under the lift remove any load from the platform, raise the lift and insert the maintenance devices, as shown in Figure 1. Do this every time you work under the lift!

### **⚠️ WARNING**

Release of fluids under high pressure can cause personal injury. Before you open any part of the hydraulic system, be sure to release the hydraulic pressure.

### **⚠️ CAUTION**

•The warning labels on the lift are there for the safety of the operators. If the labels are worn or missing, or have been painted over, replace them before releasing the lift for operation.

### **⚠️ WARNING**

If you are going to repair the center pivot pins and bushings, you must support the lift table in a special way. Each set of leg plates, on both sides of the unit, must be clamped together firmly, using large C-clamps. You cannot use the maintenance devices shown in Figure 1 – with the pivot pins removed, they will not support the table top. If you do not support the lift table correctly, the top may drop suddenly when you remove the pivot pins. Please contact Presto/ECO A for instructions.

### **NOTICE**

It is important to use hydraulic fluid with the correct grade and properties. See the hydraulic oil specification in this manual, Table 1.

### **⚠️ WARNING**

If a hydraulic fitting becomes loose, or if a hydraulic hose breaks, the hydraulic fluid may escape from the system under pressure. If the lift is raised when this happens, it can drop quickly. Someone may be hurt, or the lift or load may be damaged.

### **NOTICE**

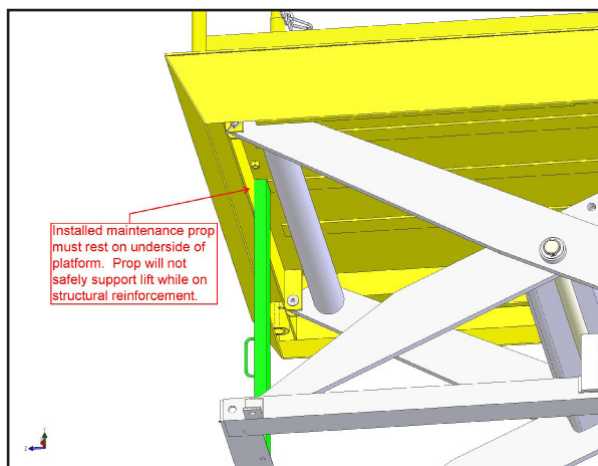
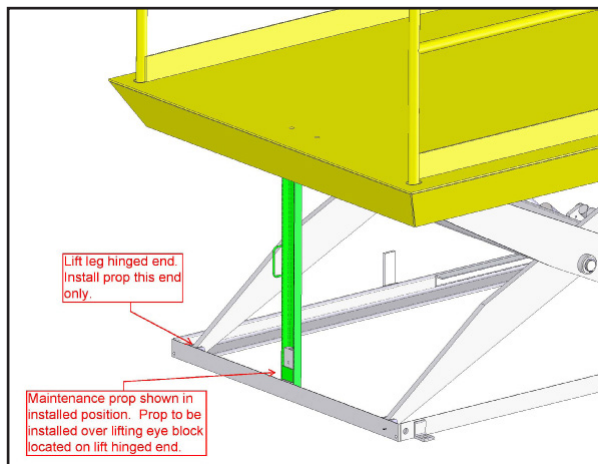
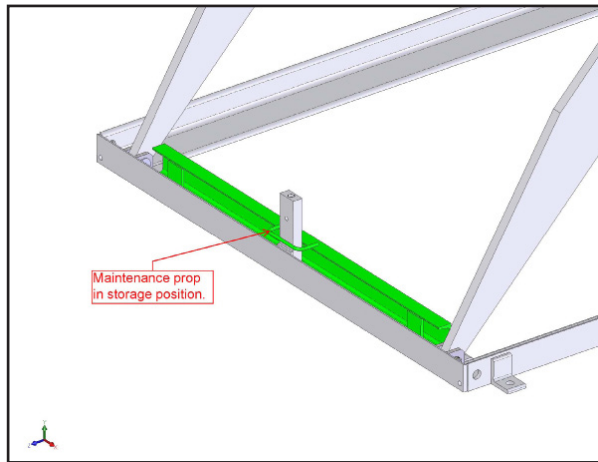
If you continue to use fluid after it has "worn out," the moving parts in the system will wear more quickly.

## FIGURE 2: Safe Servicing of the Lifts

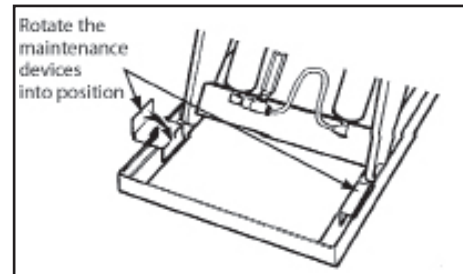
Your lift will be equipped with one of these maintenance devices

**Note:** In some cases the upper travel limit switch may need to be overridden to utilize the maintenance devices

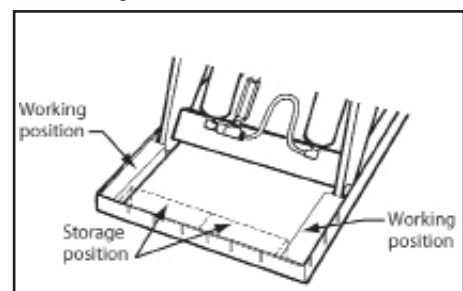
### Maintenance Bar



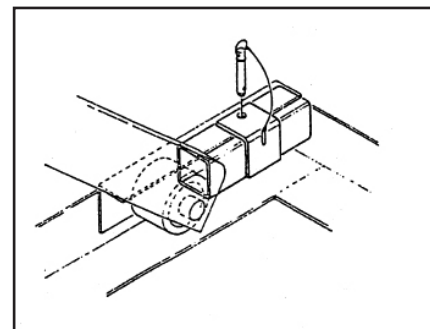
### Flip in Style



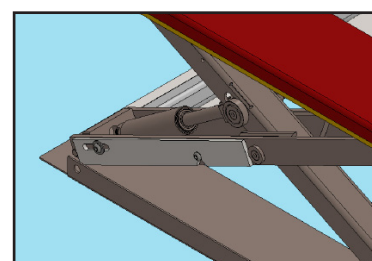
### Block Style



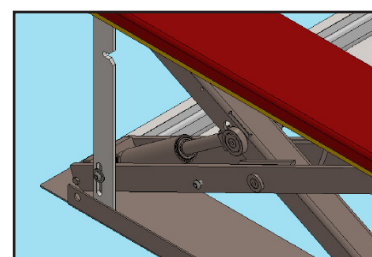
### Block Style



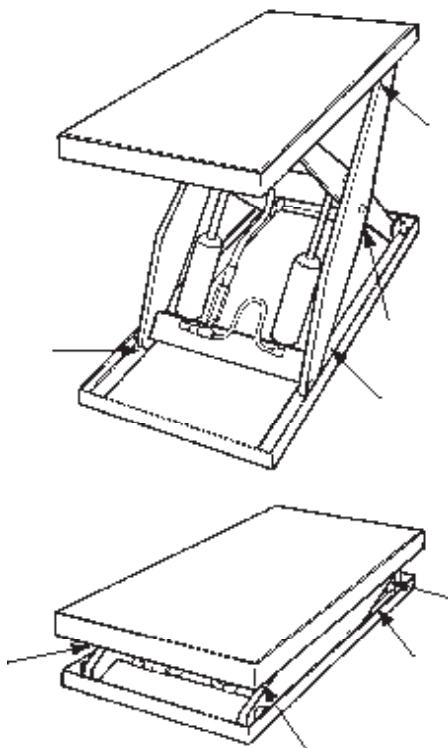
### Maintenance Chock



Maintenance Chock Disengaged (stored position)



Maintenance Chock Engaged



**FIGURE 2:**  
*Pinch Points for Typical Scissor Lift.*

reinstalled any any electrical by-pass is removed before operating the lift. Any final adjustment of limit switch needs to occur with the legset and platform supported while working under the lift. If you do by-pass or remove the switch, when the lift platform moves up, it may not stop at the correct point. If the platform rises above the normal stopping point, the frame of the unit may be damaged. People working nearby may be hurt.

**NOTICE**

If cavitation is allowed to continue, the pump may be damaged, and may have to be replaced.

**If the lift elevates, but fails to hold a load:**

**⚠WARNING**

Failure to insert the maintenance devices may result in damage to the lift and severe personal injury!

**If the lift fails to lower:**

**⚠WARNING**

Failure to insert the maintenance devices may result in damage to the lift and severe personal injury!

**⚠DANGER**

Do not try to adjust the flow control while pressing the “down” button. If you try this, the lift table may drop suddenly, and you may be hurt.

**If the lift will not raise:**

**NOTICE**

Do not continue to hold the “up” button for more than 2 or 3 seconds. You may damage the pump.

**⚠WARNING**

Do not change the relief valve setting. This valve has been included for the protection of workers who install, use, or service the lift. If it is ever necessary to repair or reset the valve, contact Presto/ECO for instructions.

**⚠WARNING**

It maybe necessary to electrically by-pass the up limit switch to place the lift on the chocks. Ensure that doing so will not operate the switch beyond its arms physical limits. This needs to be done by qualified maintenance personnel. If electrical by-pass is not possible the up limit switch needs to be moved in order to place the unit on the maintenance devices, then the lift platform and legs will need to be supported before working on the switch, support the top and leg sets with a crane, fork truck or blocking from the floor to table top. Ensure switch is properly

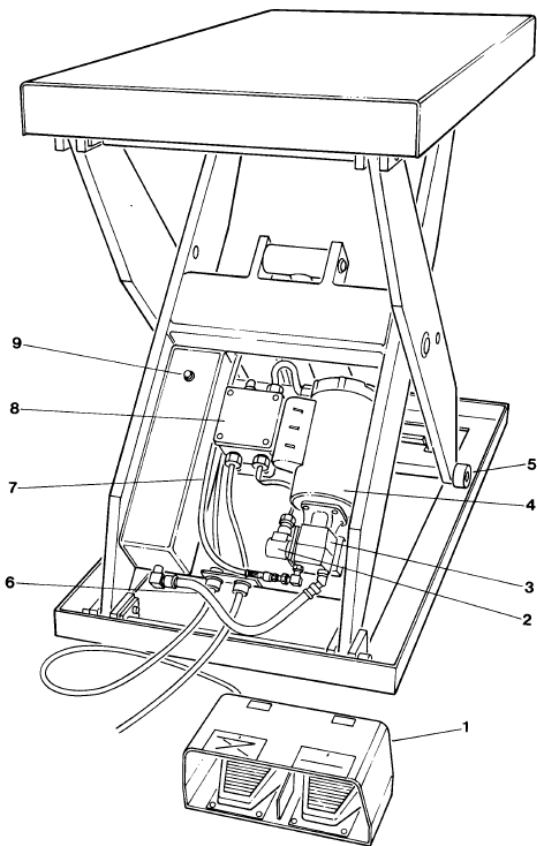
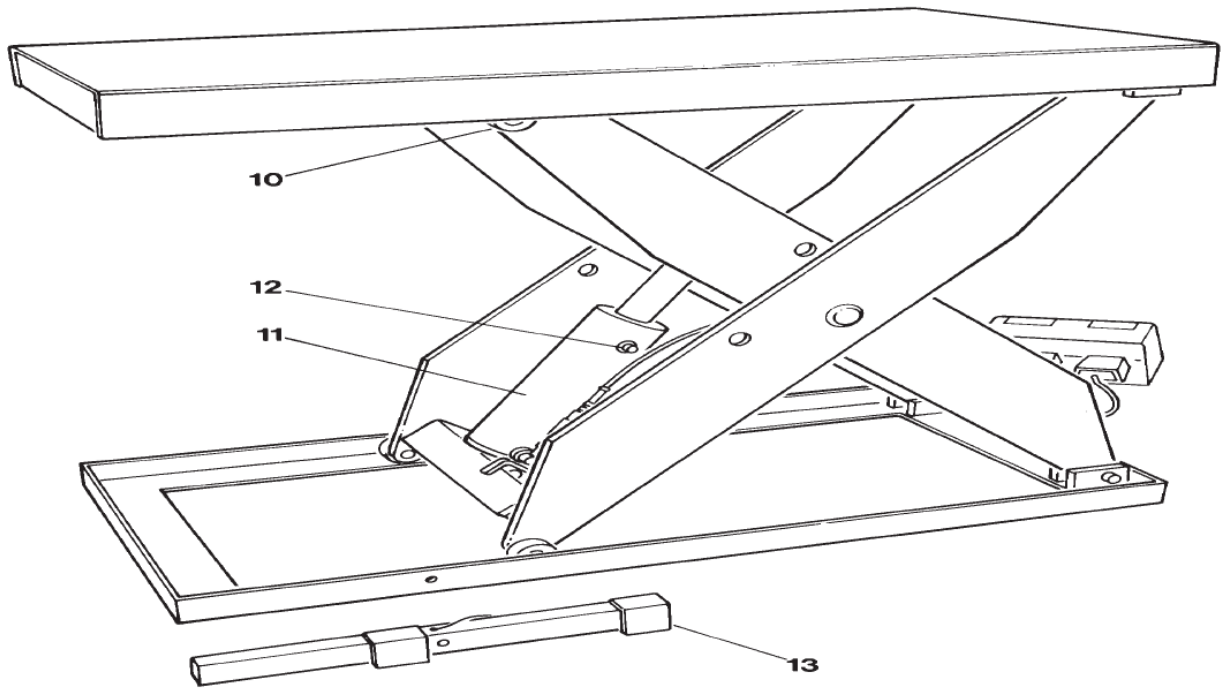
# ROUTINE PERIODIC MAINTENANCE

Suggested Preventative Maintenance Schedule (ensure that lift is properly chocked as required).

<b>Weekly</b>	Inspect leg rollers, center pivot pins and bushings, leg hinge pins and bushings for evidence of wear. loose bolts or broken cotter pins or keepers. Repair or replace as required.
<b>Monthly</b>	Apply a light oil or PTFE lubricant to non-greased pivot points or rollers described above.
	Check the appearance of the hydraulic fluid.
	Check all the hydraulic fittings and hoses.
	Make all weekly checks, check limit switch if applicable.
<b>Every 6 months or 500 hours of operation</b>	Check all the hydraulic fittings and hoses, and repair the connections.
	Inspect cylinder return line and rod. Appearance of considerable fluid in the vent lines indicates a need to repack the cylinder.
	Disassemble the down valve. Blow the plunger clean with compressed air. Reassemble and install.
	Change oil in reservoir, clean the suction screen and vent cap. Replace pressure line or return line filter element.
	Make all weekly, and monthly checks, check all electrical connections..
	<b>NOTE:</b> If bushings at the main pivot points are neglected and allowed to oblong, major structural problems will develop and extensive repairs will be needed.
<b>Minimum Required Maintenance for Units with High Cycle Package</b>	Every 10,000 cycles, visually inspect the entire lift. Replace all worn or broken parts. Lubricate all pivot points and clean the roller track.
	Every 30,000 cycles, visually inspect the entire lift. Check the motor starter contacts and limit switches. Clean and lubricate all pivot points. Inspect for worn or broken parts, and replace as necessary.
	Every 90,000 cycles, visually inspect the entire lift. Check the hydraulic tank and the hydraulic lines. Clean and lubricate all pivot points. Inspect for worn or broken parts, and replace as necessary. Repack the cylinder(s), and replace the hydraulic oil and filter.
	<b>NOTE:</b> If lubrication points will not take grease, ensure that the load has been removed from the platform, and ensure the grease fittings are not plugged and will take grease, or the weight of the lift may need to be removed from the greaseable joint. A fork truck or overhead crane may be necessary to remove any weight off of the greaseable joints. Contact Presto-ECO Service Department for further instructions if the machine is still unable to accept grease.

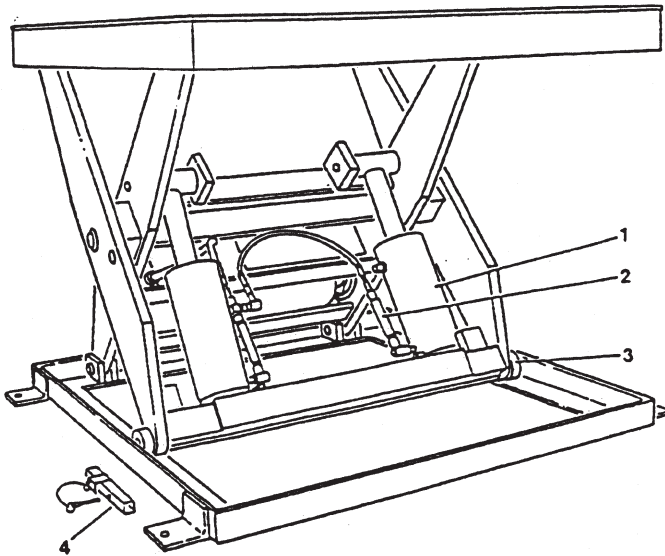


**FIGURE 3: XL & HLT SCISSOR LIFTS**



ITEM #	DESCRIPTION
1	Foot Control
2	Down Solenoid Coil
3	Pump
4	Motor
5	Roller
6	Suction Line
7	Pressure Line
8	Control Panel
9	Fill Plug
10	Upper Roller
11	Cylinder
12	Vent
13	Roller Chock

**FIGURE 4:  
EXPOSED CYLINDER ASSEMBLY**



ITEM #	DESCRIPTION
1	Cylinder
2	Velocity Lock or Excess Flow Protector
3	Roller
4	Wheel Chock

**FIGURE 5:  
EXPOSED POWERPACK**

ITEM #	DESCRIPTION
1	Motor
2	Pump
3	Reservoir
4	Fill Plug
5	Control Box

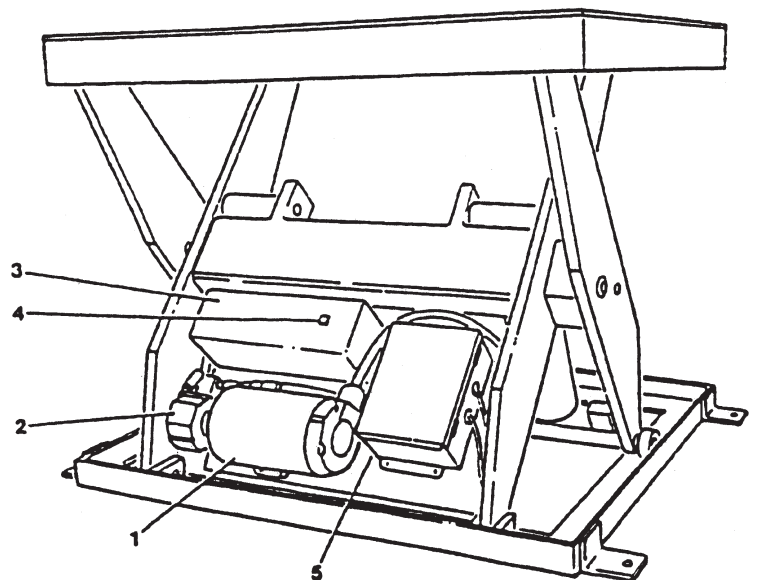
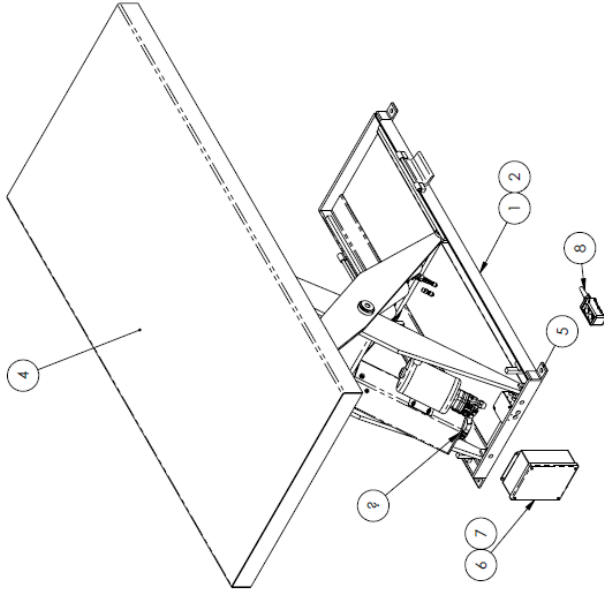
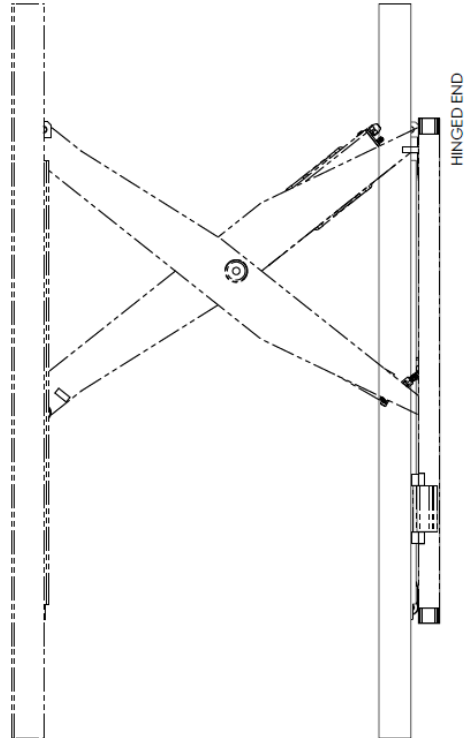
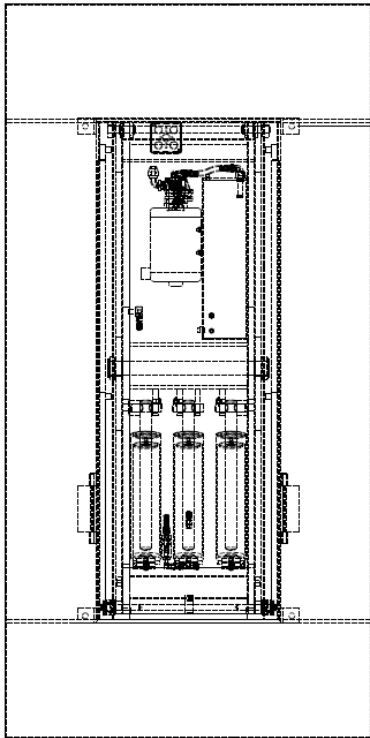


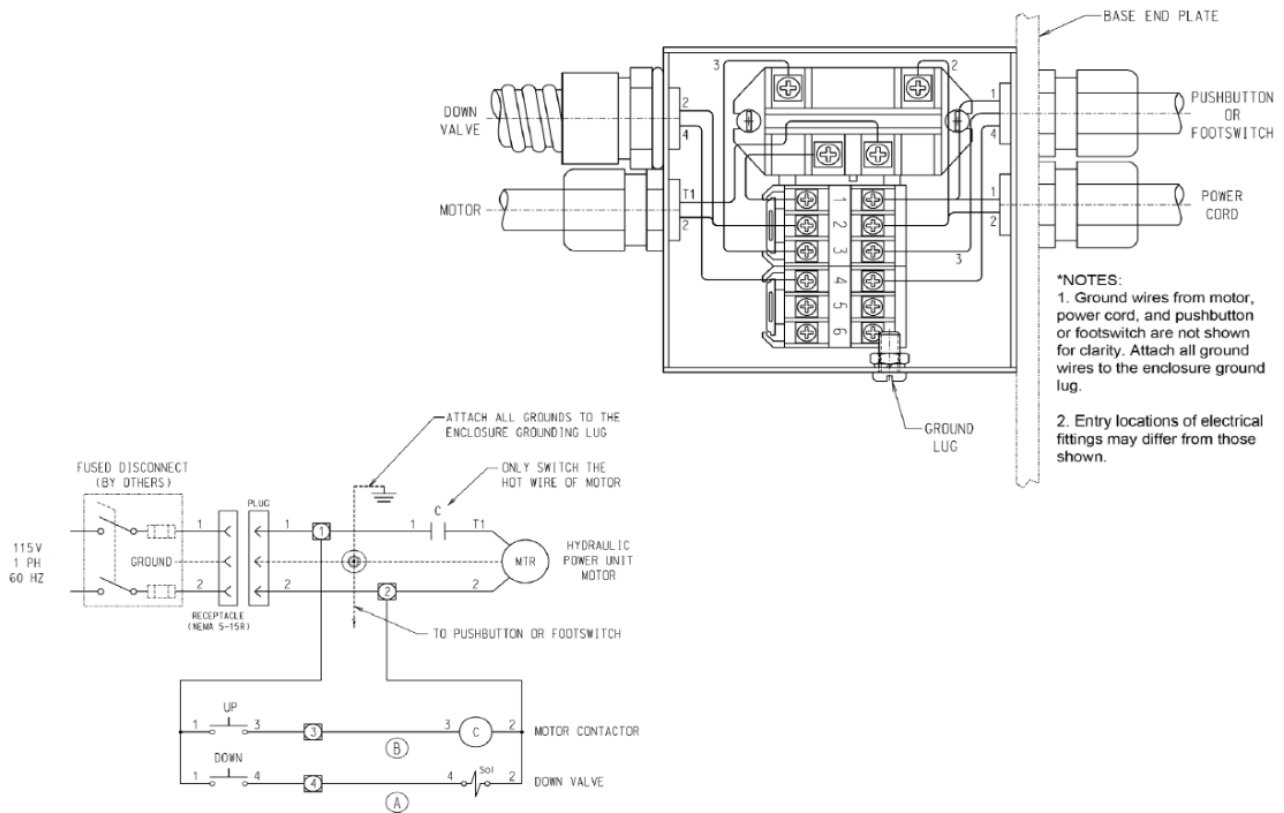


FIGURE 6: HLT - GENERAL DESCRIPTION WITH DRAWINGS

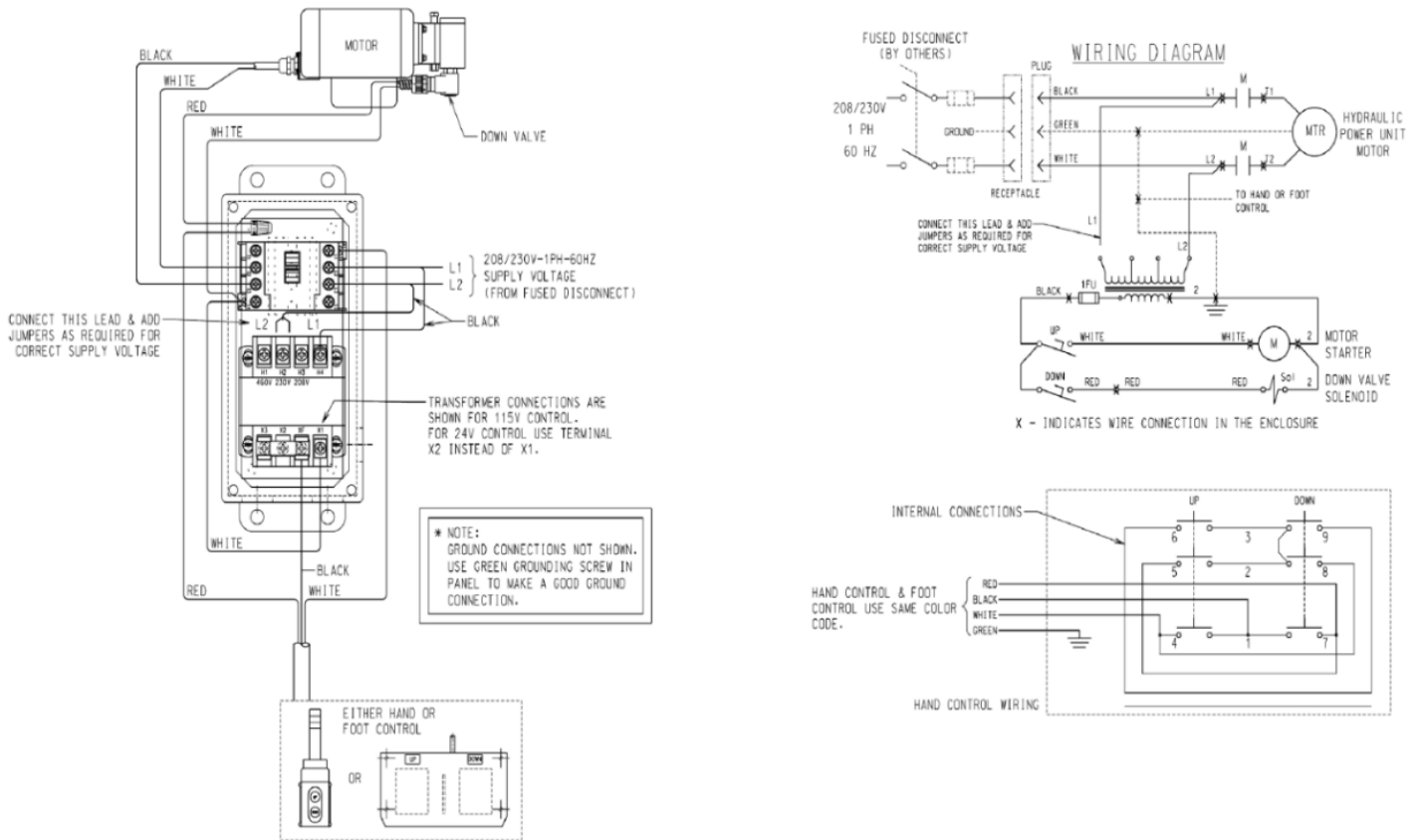


 3RD ANGLE PROJECTION		FRACTIONS: $\frac{1}{8}$ $\frac{3}{32}$ $\frac{1}{4}$ ANGLES: $\frac{1}{4}$ $\frac{1}{2}$ $3/4$	ITEM NO.   QTY.   U/M   DESCRIPTION	PART NO.   DATE
PROJECT: B37741 USE OF PROPRIETARY INFORMATION LIMITED BY WRITTEN AGREEMENT		UNLESS OTHERWISE SPECIFIED, DIMENSIONS ARE IN INCHES	PRESTO LIFTS / ECOA INC. 50 Commerce Way Norton MA 02766 REFERENCE: 4438243   CAGE CODE: 06828   WT: 1208.53 LB   SCALE: 1:12   MODEL: L56-48	BCHK:   DATE: 12/05/16 CK:   DATE:
STATUS: Released		FILE:	SIZE: DWG. NO.   SHEET   OF:   REV	C   1   1   1

**FIGURE 7: WIRING SCHEMATIC 115/1/60 power**

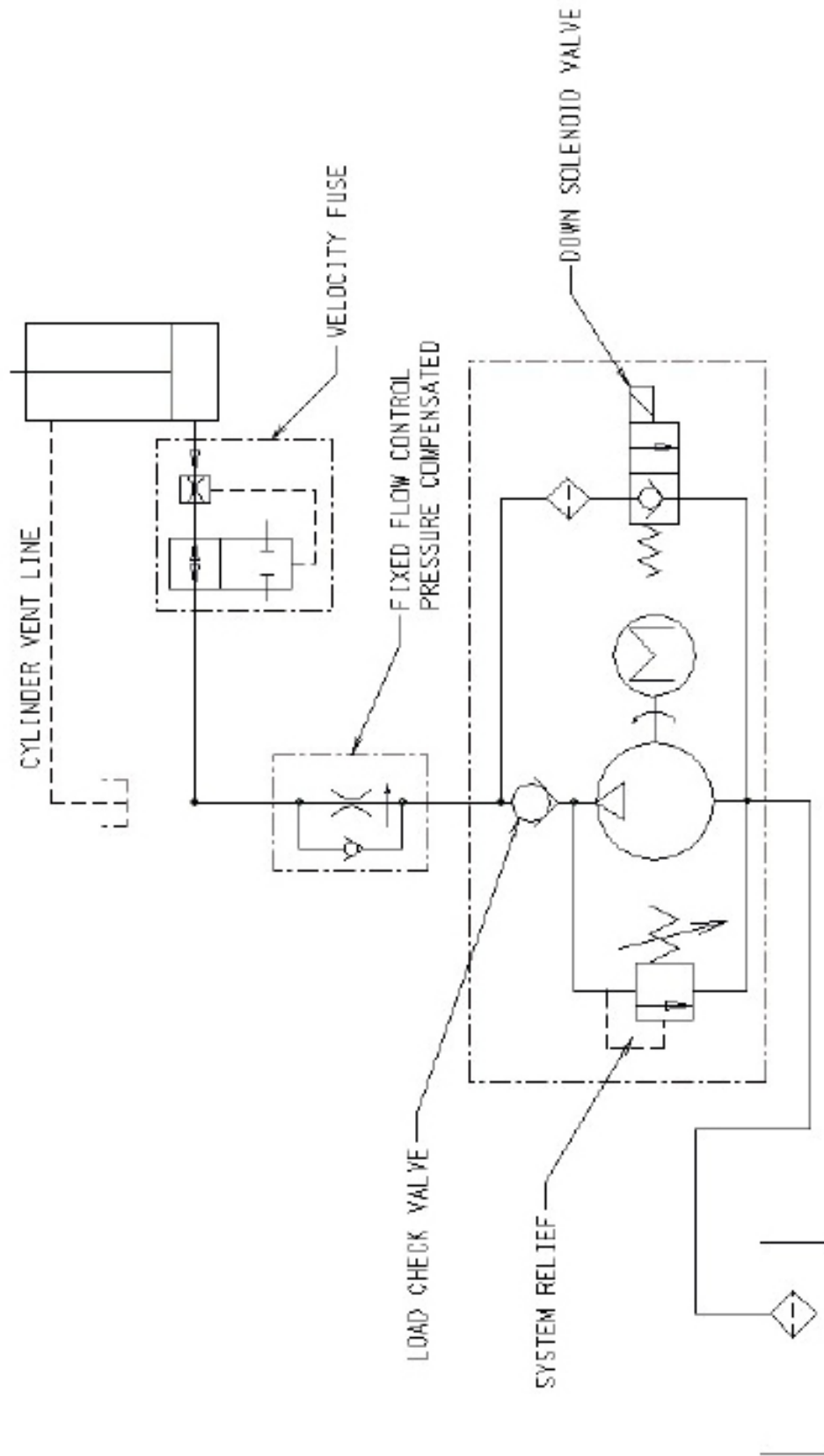


**FIGURE 7A: WIRING SCHEMATIC 208,230/1/60 power**

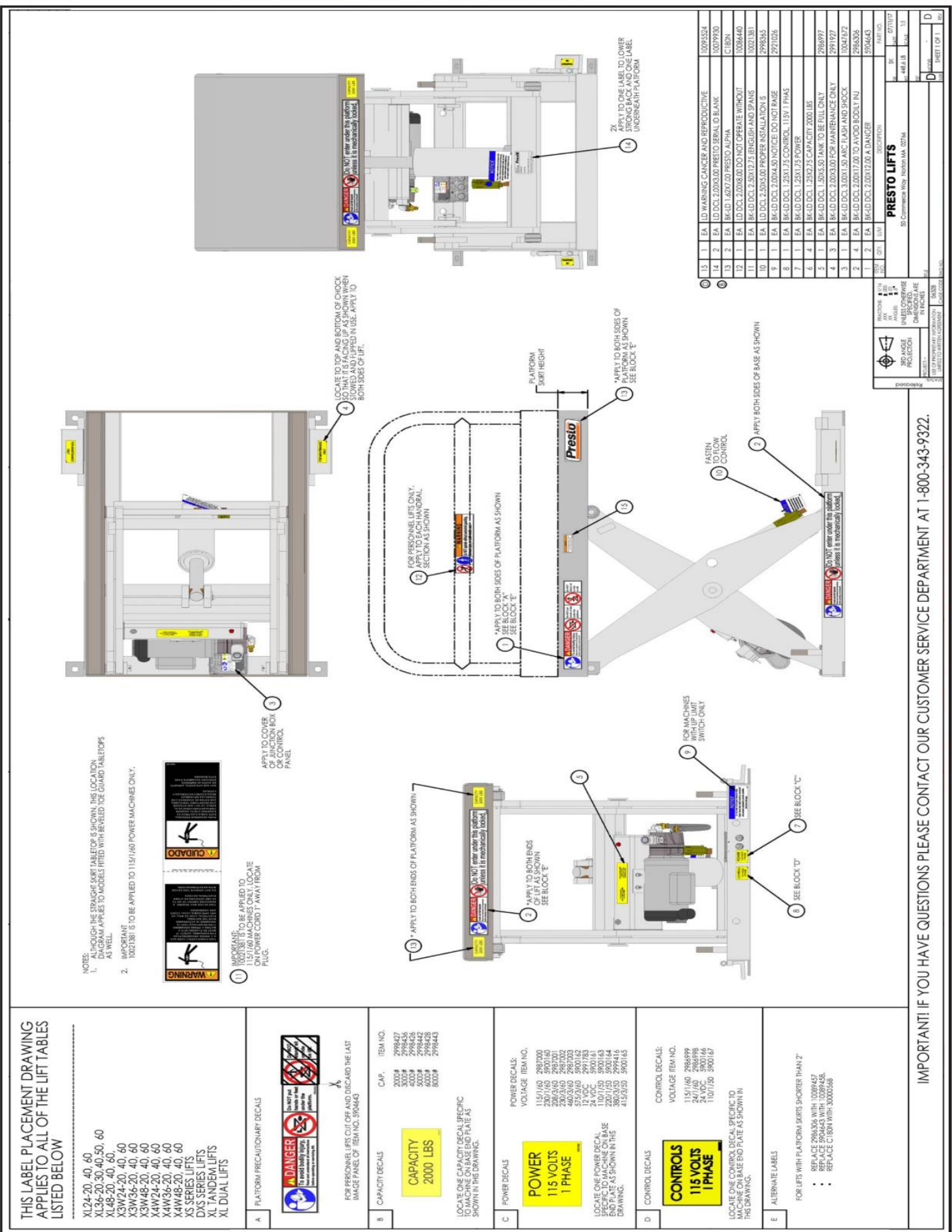




**FIGURE 9: HYDRAULIC SCHEMATIC for all MODELS**

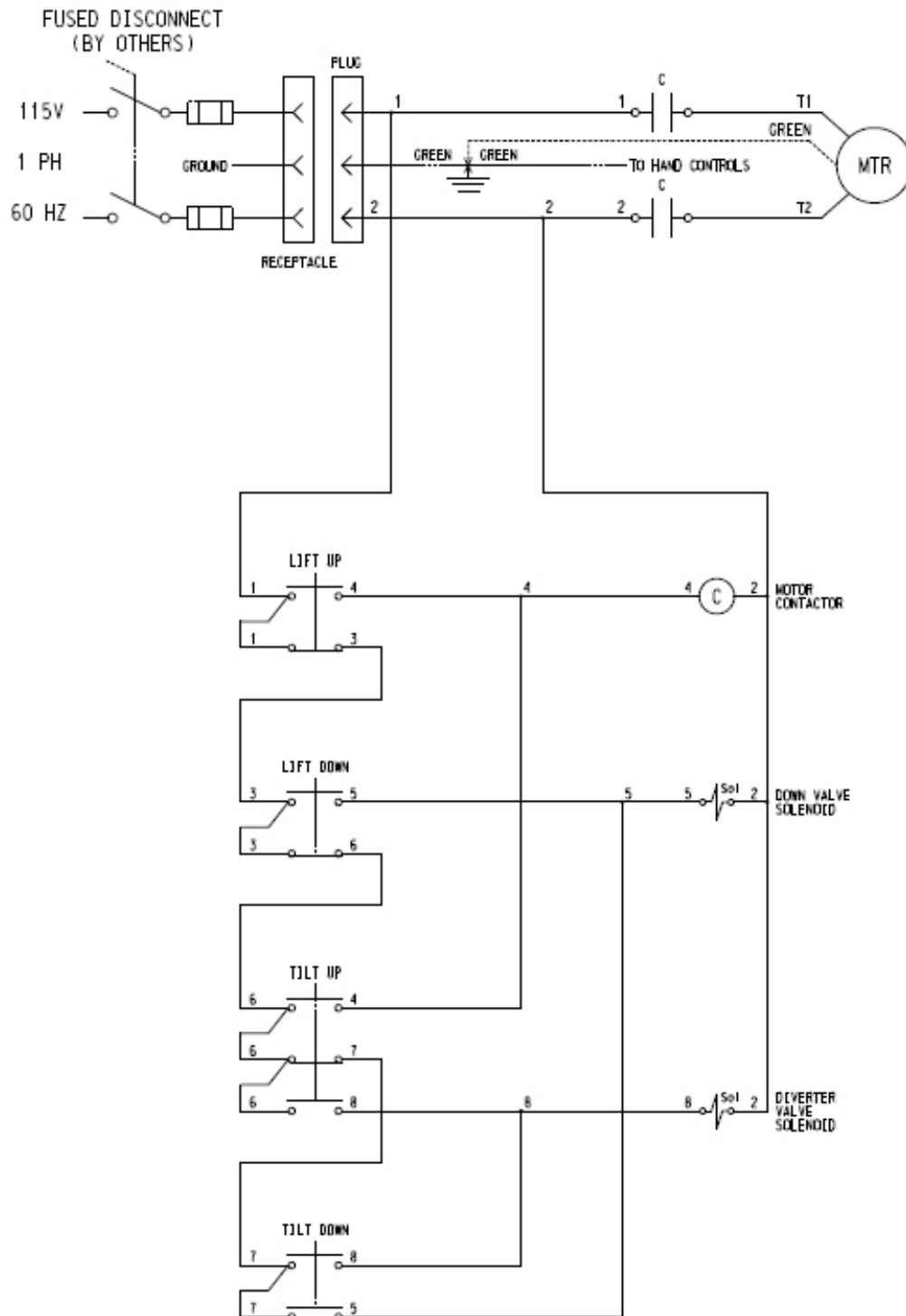


**FIGURE 10: LABELING DIAGRAM for all MODELS**

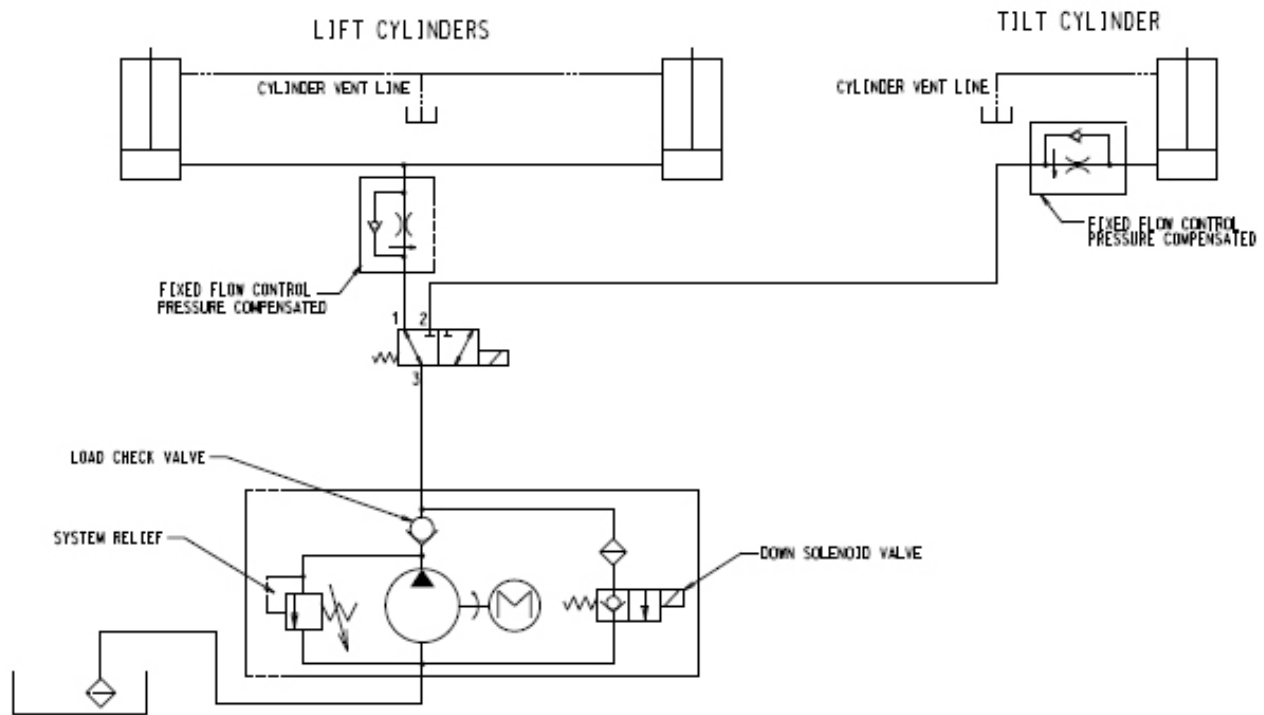


**FIGURE 11: WIRING DIAGONAL 115 AC NO TRANSFORMER**

\* NOTE:  
GROUND CONNECTIONS NOT SHOWN  
USE PROPER GROUND PROCEDURES.



**FIGURE 12: PLUMBING SCHEMATIC**



**Table 1 – Hydraulic Oil Specifications**

If the lift will be used at normal ambient temperatures, Presto-ECO Lifts supplies the unit with Conoco Super Hydraulic 32 oil. This may be replaced by any other good quality oil with 150 SSU at 100° F and rust and oxidation inhibitors and anti-wear properties.

If the lift will be used at ambient temperatures below 0°F, use aircraft hydraulic oil. Use Type 15 aircraft hydraulic oil.

The following are equivalent to Conoco Super Hydraulic 32:

TYPE	MANUFACTURER
AW32.....	CITGO
DTE 24 .....	EXXON/MOBIL
NUTO H32 .....	EXXON/MOBIL
AMOCO AW32 .....	CHEVRON (AMOCO CO.)

**CAUTION!**

It is very important to keep the hydraulic oil free of dirt, dust, metal chips, water, and other contamination.

Most of the problems with hydraulic systems are caused by contamination in the oil.

## **PARTS**

Standard parts may be returned with a 20% restocking fee or \$35.00 net, whichever is greater. Modified or custom-engineered parts are not returnable. Unfortunately, due to potentially concealed damage, all sales of electrical assemblies are final.

## **QUALITY ISSUES**

Should you feel there is a quality problem, please contact the seller to ask questions and gather information on how to rectify the issue. Presto-ECO Lift reserves the right to determine potential credits, as a result of factory defects, based on its inspection of the merchandise.

## **GENERAL**

All products shipped from our factory have passed Quality Assurance inspection and testing. The carrier of choice has signed for, and accepted the product in new working condition. The customer should inspect to ensure it is not received damaged, has no concealed damage or is not incomplete. Parts orders are determined to be complete based upon Presto-ECO inspection sheets and carrier shipping weights.



# ORDERING REPLACEMENT PARTS

Presto-ECOALifts has carefully chosen the components in your unit to be the best available for the purpose. Replacement parts should be identical to the original equipment. Presto-ECOALifts will not be responsible for equipment failures resulting from the use of incorrect replacement parts or from unauthorized modifications to the unit.

Presto-ECOALifts can supply all replacement parts for your lift. With your order, please include the model number and the serial number of the unit. You can find these numbers on the name plate. This plate is located within the scissors mechanism.

To order replacement parts, please call the Presto-ECOALifts Parts Department. Parts are shipped subject to the following terms:

- FOB factory
- Returns only with the approval of our parts department.
- Credit cards preferred (except parts covered by warranty).
- Freight collect for truck (except parts covered by warranty).
- Freight – prepaid and invoice for small parcel shipments (except parts covered by warranty).
- The warranty for repair parts is 30 days from date of shipment.

Parts replaced under warranty are on a “charge-credit” basis. We will invoice you when we ship the replacement part, then credit you when you return the worn or damaged part, and we verify that it is covered by our warranty. Labor is not covered under warranty for Parts orders.

## **Presto-ECOALifts Parts Department**

50 Commerce Way, Norton, MA 02766

Telephone: 800-343-9322

FAX: 888-788-6496

Email: [service@PrestoLifts.com](mailto:service@PrestoLifts.com)

[www.PrestoLifts.com](http://www.PrestoLifts.com)

[www.ECOALifts.com](http://www.ECOALifts.com)



# Presto-ECO Lifts Limited Warranty Policy

Presto Lifts warrants this product to be free from defects in material or workmanship for the duration of the warranty period. Warranty periods vary and begin on the date of shipment. For specific warranty information, contact Presto Lifts with the machine's serial number.

Any claim for breach of this warranty must be received in writing by Presto Lifts within the warranty period. Warranties shall not cover failure or defective operation, caused by misuse, misapplication, negligence or accident, exceeding recommended capacities, or any alteration or repair of the item purchased which has not been authorized by Presto Lifts. Except as set forth herein, Presto Lifts makes no other warranties, express or implied, including THE WARRANTIES OF MERCHANTABILITY AND OF FITNESS FOR A PARTICULAR PURPOSE, all of which ARE HEREBY EXCLUDED.

Presto Lifts meets the labeling requirements of California's Proposition 65. Presto Lifts makes no warranty or representation with respect to the compliance of any product with other State or local safety or product standard codes and any failure to comply with such codes shall not be considered a defect of material or workmanship under this warranty. Presto Lifts shall not be liable for any direct or consequential damages arising out of such non-compliance.

Presto Lifts' obligations under any warranty or for any other damages which may arise under any sale, agreement, or contract, are limited to the replacement or repair of defective components at its factory or another location at Presto Lifts' discretion. This is buyer's sole remedy under any such warranty, sale, agreement, or contract. Presto Lifts will not be liable for consequential, incidental, exemplary, or punitive damages of any kind resulting from a breach of any warranty that it has provided or for breach of any term of any sale, agreement, or contract. Any warranty may be altered only in writing by Presto Lifts.

All commodities, software, or technology purchased from Presto Lifts are subject to the export and re-export control laws and regulations of the United States, including but not limited to the Export Administration Regulations ("EAR") and Department of the Treasury Office of Foreign Asset Controls ("OFAC") Regulations. Presto Lifts expects all distributors and customers to comply with these laws and regulations. Without limiting the foregoing, the distributor/customer cannot, without proper authorization from the applicable United States Government Agency, export, re-export, or transfer any commodity, software, or technology purchased from Presto Lifts, either directly or indirectly, to any entity, country, or national of any country in breach of such laws and regulations. Furthermore, Presto Lifts expects that the distributor/customer shall indemnify and hold harmless Presto Lifts from and against any claim, proceeding, action, fine, loss, cost and damages arising out of or relating to any noncompliance with export control regulations by distributor/customer, and distributor/customer are expected to compensate Presto Lifts for all losses and expenses resulting thereof, unless such noncompliance was clearly not caused by fault of the distributor/customer.